

D1~D39

External Turning Toolholders Identification System **D3**

Product Lineup **D4~D5**

Clamping System **D6~D7**

External Turning Toolholders **D8~D25**

CN □□ Insert	DCLN / DCLN-JCT	D8
	PCLN	D9
DN □□ Insert	DDJN / DDJN-JCT / DDHN	D12
	PDJN / PDHN	D13
SN □□ Insert	DSBN / PSBN / PSKN	D14
	PSSN / PSDN	D15
TN □□ Insert	DTGN / DTGN-JCT	D16
	PTGN / PTFN	D17
	WTJN-N / WTKN-N / WTEN-N	D18
VN □□ Insert	DVLN / DVPN / DVVN	D19
	DVLN-JCT / DVPN-JCT / DVVN-JCT	D20
	MVLN / MVVN	D21
	PVLN / PVPN / PVVN	D22
RC □□ Insert	PRGC / PRXC	D23
RN □□ Insert	PRGN	D23
WN □□ Insert	DWLN / DWLN-JCT	D24
	PWLN / WWLN	D25

Toolholders for Ceramic Tools **D26~D31**

CN □□ Insert	CCLN	D26
DN □□ Insert	CDJN	D27
EN □□ Insert	CELN	D27
SN □□ Insert	CSRN / CS-N / CSKN / CSYN / CSSN / CSDN	D29
TN □□ Insert	CTJN / CTUN	D30
RN □□ Insert	CRSN / CRDN	D31

Toolholders for Solid CBN Tools **D32~D36**

CNMN Insert	CCRN-A / CCLN-A	D32
RNMN Insert	CRSN-A / CRDN-A	D33
SNMN Insert	CSRN-A / CSKN-A	D34
	CSSN-A / CSDN-A	D35
TNMN Insert	CTJN-A	D36

Toolholders for Bearing Machining **D37**

RCMT Insert / SNMF Insert	PRGC-BE / CBSN	D37
---	----------------	------------

Technical Information **D38~D39**

Recommended Cutting Conditions	D38
---------------------------------------	------------

Parts Compatibility of Lever Lock Toolholders **R55**



D

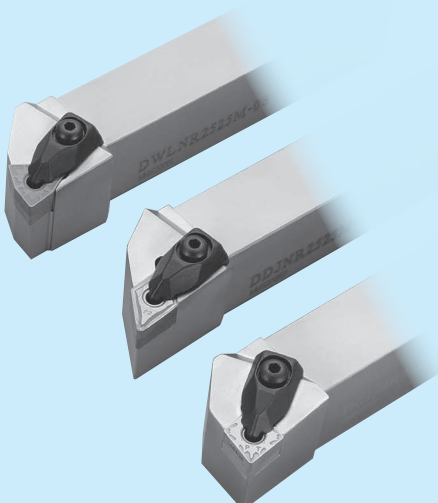

Coolant-through Holders

Great for High Pressure Coolant Turning Toolholders

Double Clamp-JCT

Improved Chip Control and Longer Tool Life for a Wide Variety of Workpieces including Steel, Hardened Material and Difficult-to-Cut Material

D

External

Special Coolant Hole Design

Special coolant-through structure designed by careful simulation and analysis technology

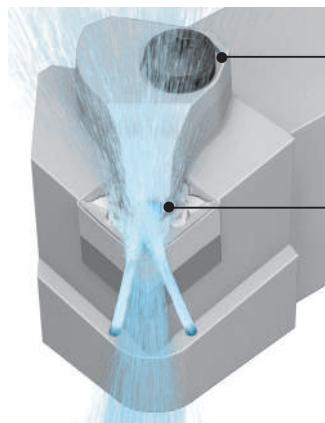

Double Clamp

Firm insert clamp and easy to use in single operations
High-density coolant supply close to the cutting edge

Unique Nozzle Shape

Provides coolant to a wide area of the insert surface

○ : Coolant Hole

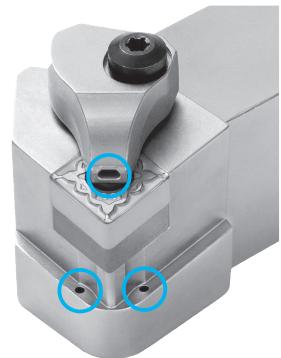

Discharges Coolant in Three Directions
The Cutting Edge Stays Cool

*The coolant supply system depends on the type
DTGN-JCT,DVLN/DVPN-JCT : Two directions, DVVN-JCT : One direction

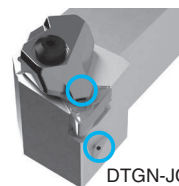

DTGN-JCT



DVVN-JCT

Internal Coolant Benefits

Discharges Coolant towards the Cutting Edge

Internal Coolant Provides Longer Tool Life and Excellent Chip Control

Longer Tool Life

Wear Resistance Comparison (Internal evaluation)

Internal coolant (7MPa)

External coolant (0.4MPa)

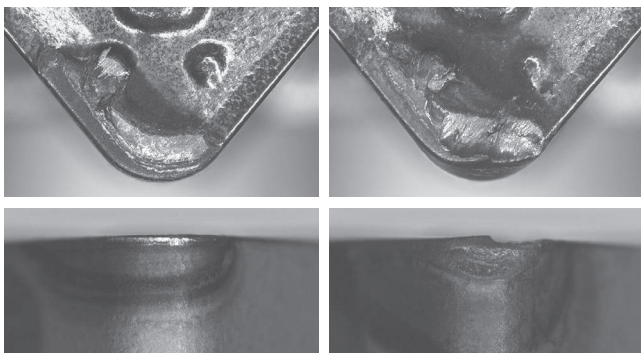

Cutting Conditions : $V_c = 250$ m/min, $a_p = 2$ mm, $f = 0.3$ mm/rev, Wet
CNMG120408type Workpiece Material : SCM435
External After Machining 42.2 min

Improved Chip Control

Chip Control Comparison (Internal evaluation)

Internal coolant (7MPa)

External coolant (0.4MPa)

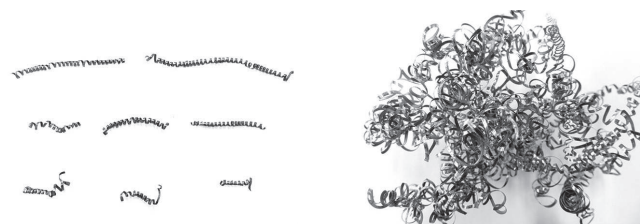

Cutting Conditions : $V_c = 200$ m/min, $a_p = 0.5$ mm, $f = 0.05$ mm/rev, Wet
DNMG150408type Workpiece Material : SCM415 External

External Turning Toolholders Identification System (Square Shank)

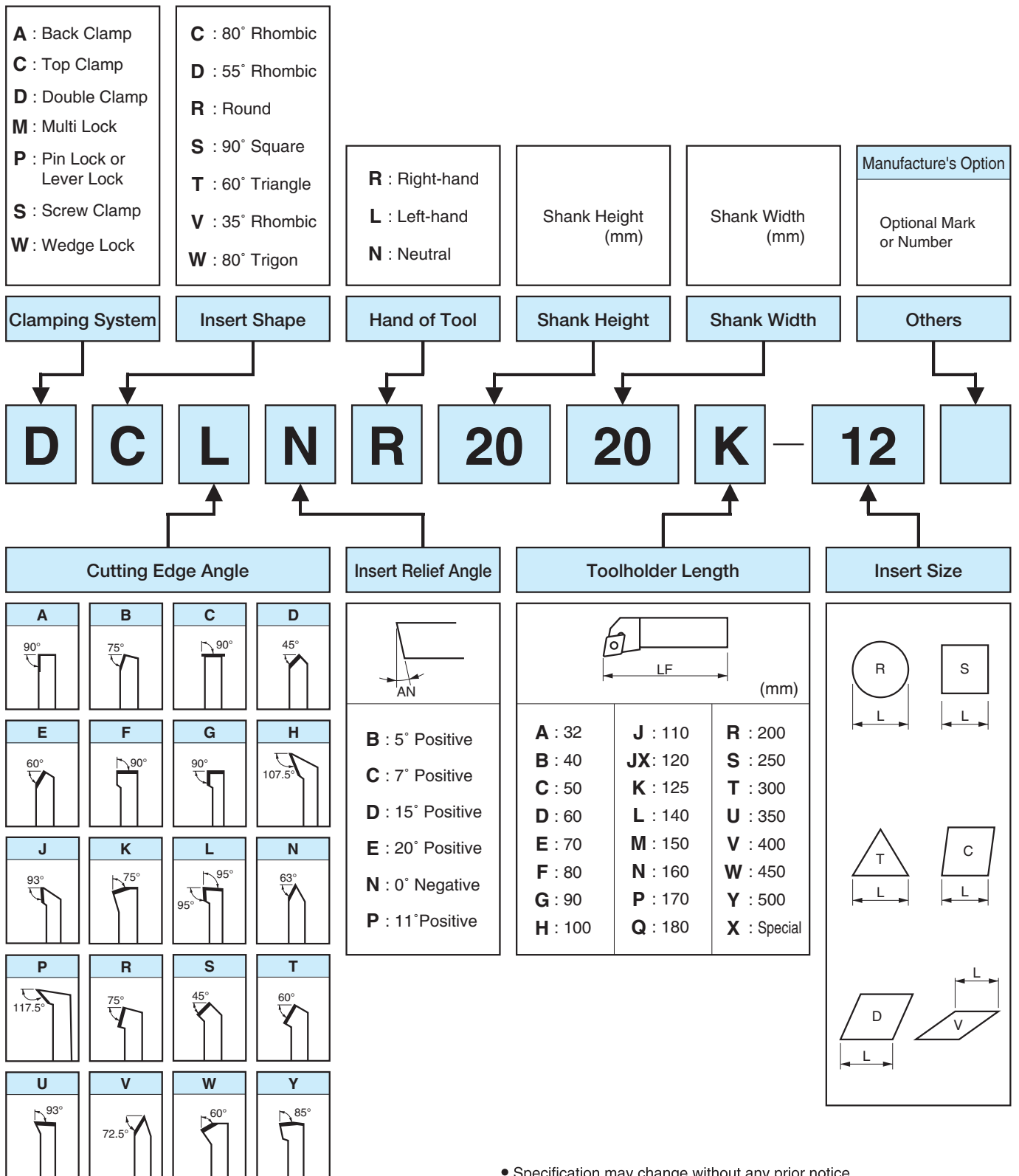

- Specification may change without any prior notice.
- Due to the installation size constraints on the machine, the toolholder length of some products may not match with the symbol.

Insert Grades
 Turning
 Indexable Inserts
 CNX & PCD Tools
 External
 Small Parts
 Machining
 Boring
 Grooving
 Cut-off
 Threading
 Drilling
 Milling
 Tools for
 Turning Mill
 Spare Parts
 Information
 Index

Product Lineup

External Turning Toolholders

Applicable Insert Shape	CN..	WN..	TN..	DN..	RC..		RN..	VN..
Applications	External / Facing			External / Facing / Copying				External / Facing / Copying / Undercutting
Cutting Edge Angle	95°		105°	107.5°	Special			117.5°
Lever Lock (Pin Lock)								
See Page	D9	D25		D13	D23	D23	D23	D22
Wedge Lock Multi Lock								
See Page		D25	D18					
Double Clamp (Coolant-through Holders)								
See Page	D8	D24		D12				D19 / D20

Toolholders for Ceramic Tools

Applications	External / Facing			External / Copying	External / Chamfering	External / Facing / Chamfering	
Cutting Edge Angle	95°	97.5°	Special	93°	Special	45°	45°
Top Clamp							
See Page	D26	D27	D31	D27	D31	D29	D29

Toolholders for Solid CBN Tools

Applications	External / Facing		External / Copying	External / Chamfering	External / Facing / Chamfering	External		
Cutting Edge Angle	95°	Special	Special	45°	45°	75°		93°
Top Clamp								
See Page	D32	D33	D33	D35	D35	D32	D34	D36

D

External

	VN..		DN..	SN..	TN..	SN..	SN..	TN..	SN..	TN..
			 TN..							
	External / Copying			External / Chamfering		External / Facing / Chamfering	External		Facing	
	72.5°	95°	93°	45°	60°	45°	75°	91°	15°	-1°
	MVVN D21	MVLN D21	WTJN-N D18		WTEN-N D18					
	DVVN (-JCT) D19 / D20	DVLN (-JCT) D19 / D20	DDJN (-JCT) D12				DSBN D14	DTGN (-JCT) D16		

	External			Facing		
	75°	85°	93°	5°	15°	-3°

Toolholders for Bearing Machining

Facing
15°
D34

Applications	External
Cutting Edge Angle	Special
Lever Lock	
See Page	D37

Applications	Round Chamfering
Cutting Edge Angle	Special
Top Clamp	
See Page	D37

Clamping System

Clamping System

Series	Design		Features	Series	Design		Features
Top Clamp (C)			<ul style="list-style-type: none"> · Rigid Clamping · Negative Insert : Medium to Heavy Machining (Mainly for Ceramic Insert) · Positive Insert : Low Cutting Force 	Multi Lock (M)			<ul style="list-style-type: none"> · Combination of Top Clamp and Pin Lock · Rigid Clamping · Heavy Machining
Double Clamp (D)			<ul style="list-style-type: none"> · Firmly clamp the insert in two directions with one action 	Lever Lock (P)			<ul style="list-style-type: none"> · Easy Insert Replacement · General Use
Pin Lock (P)			<ul style="list-style-type: none"> · Easy Insert Replacement 	Wedge Lock (W)			<ul style="list-style-type: none"> · Rigid Clamping · Heavy Machining
Screw Clamp (S)			<ul style="list-style-type: none"> · Simple Mechanism · Fewer Parts · Finishing to Medium Machining 				

● Lever Lock

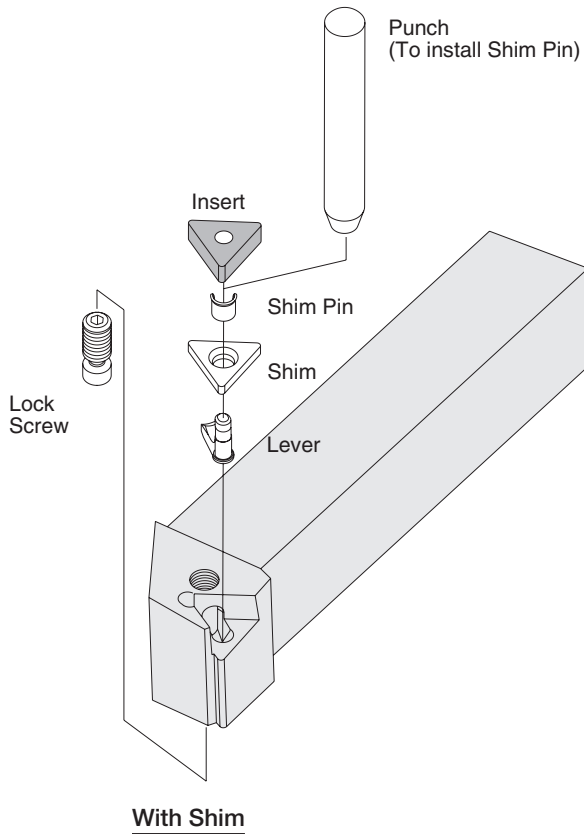

PCLN
 PWLN
 PTGN / PTFN / PTLN
 PDJN / PDHN
 PSBN / PSKN / PSSN / PSDN
 PRGN
 PRGC / PRXC

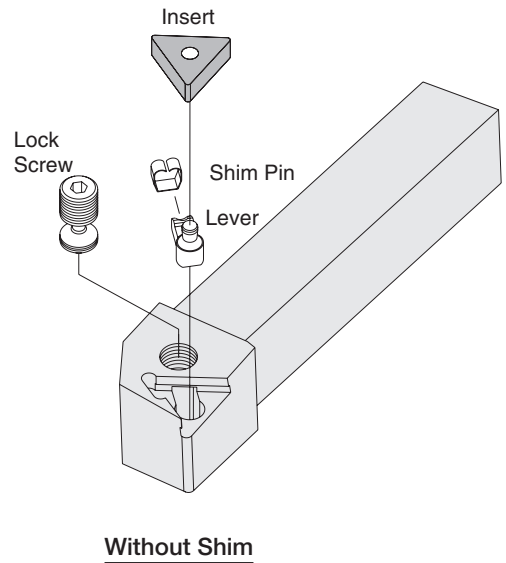

PTGN-11 / PTFN-11

D
External

● Double Clamp

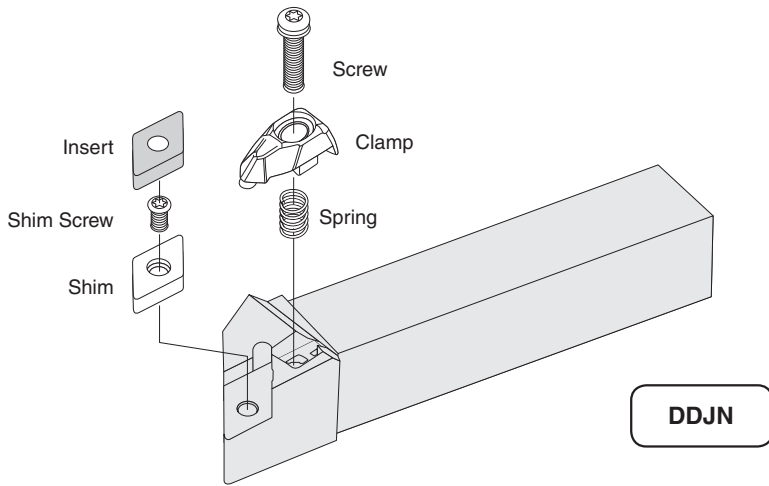

DCLN
DDJN / DDHN
DSBN
DTGN
DVLN / DVPN / DVVN
DWLN

DDJN

● Wedge Lock

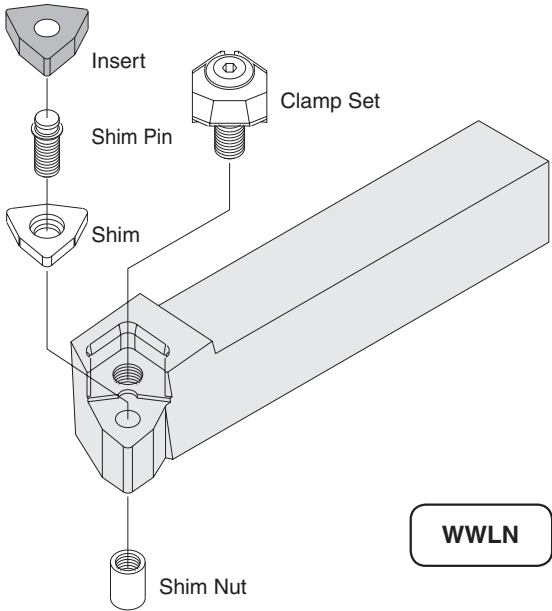

WWLN

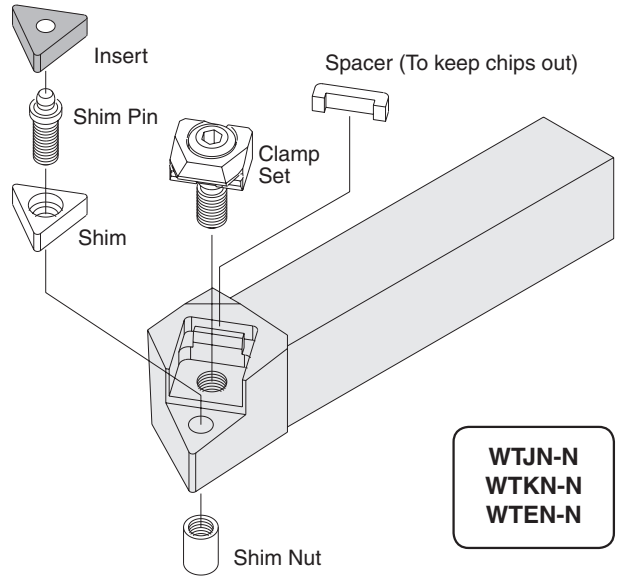

WTJN-N
WTKN-N
WTEN-N

● Multi Lock

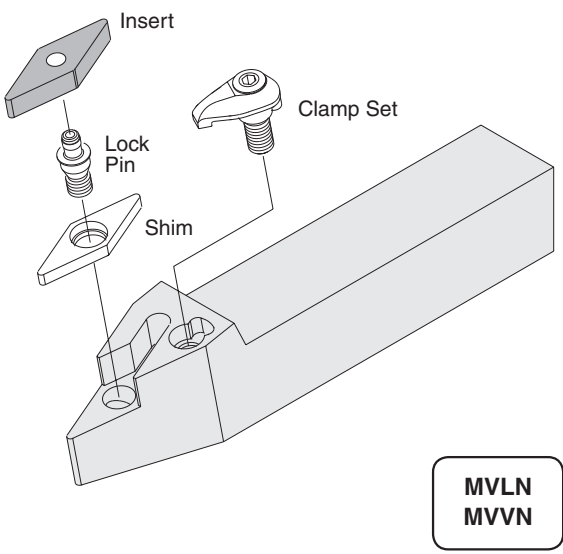

MVLN
MVVN

● Top Clamp

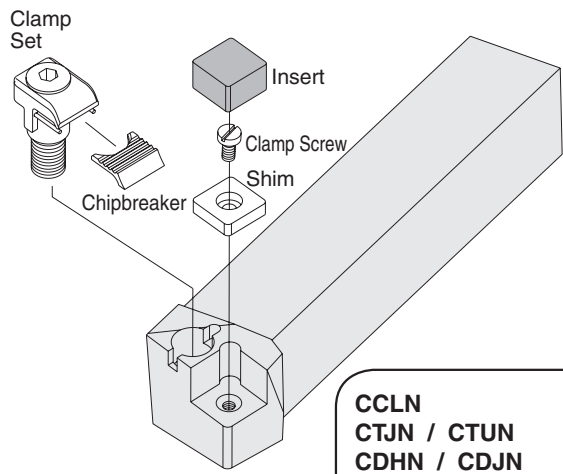

CCLN
CTJN / CTUN
CDHN / CDJN
CELN
CSRN / CS-N / CSKN
CSYN / CSSN / CSDN
***CRSN / *CRDN**

* A chipbreaker is not included with CRSN / CRDN.

Insert Grades	A
Turning Indexable Inserts	B
CBN & PCBN Tools	C
External	D
Small Parts Machining	E
Boring	F
Grooving	G
Cut-off	H
Threading	J
Drilling	K
Milling	M
Tools for Turning Mill	N
Spare Parts	P
Technical Information	R
Index	T

DCLN (External / Facing)

Side Rake Angle : -6°
Angle of Inclination : -6°

● Applicable Inserts

Toolholder Description	Insert Description
DCLN ^{F/L} ...-12	CN□A CN□G CN□M 1204..

● Right-hand shown

● Toolholder Dimensions

Description	Stock		Dimension (mm)							Std. Corner-R(RE)	Spare Parts						
	R	L	H	HF	B	LF	LH	WF	Clamp		Screw	Spring	Shim	Shim Screw	Wrench	Wrench (sold separately)	
DCLN ^{F/L} 2020K-12	●	●	20	20	20	125	33	25	0.8	CP-3D	CS-3D	SP-3D	*1DC-44	SB-4085TR	LW-3	FT-15	
2525M-12	●	●	25	25	25	150	32	32					*2DC-44-C				

*1. When using inserts whose corner-R(RE) is greater than 1.6mm, additional modifications to the shim are necessary in order to prevent workpiece and shim from interfering each other.
 *2. When using the inserts with SX chipbreaker, prepare a shim separately.
 · Recommended tightening torque 3.9N·m

DCLN-JCT (External / Facing and Coolant-through Holders)

Pressure Resistance : ~30MPa

Side Rake Angle : -6°
Angle of Inclination : -6°
Coolant supply: 3 directions

● Applicable Inserts

Toolholder Description	Insert Description
DCLN ^{F/L} ...-12	CN□A CN□G CN□M 1204..

● Right-hand shown

● Toolholder Dimensions

Description	Stock		Dimension (mm)							Std. Corner-R(RE)	Spare Parts						
	R	L	H	HF	B	LF	LH	WF	MHD		Clamp	Pipe Connection (*1 with O-ring)	Screw	Spring	Shim	Shim Screw	Wrench
DCLN ^{F/L} 2020K-12JCT	●	●	20	20	20	125	27	25	109	0.8	CP-3D- ^{F/L} -JCT	FP-12	CS-3D-TR	SP-3D	*2DC-44	SB-4085TR	FT-15
2525M-12JCT	●	●	25	25	25	150	27	32	134					*3DC-44-C			

Please see page D10 and D11 for piping parts of coolant-through holders.

*1 It is possible to order just an O-ring (SS-035).

*2. When using inserts whose corner-R(RE) is greater than 1.6mm, additional modifications to the shim are necessary in order to prevent workpiece and shim from interfering each other.

*3. When using the inserts with SX chipbreaker, prepare a shim separately.

· Recommended tightening torque 3.9N·m

PCLN (External / Facing)

• Right-hand shown

Side Rake Angle : -6°
Angle of Inclination : -6°

● Applicable Inserts

Toolholder Description	Insert Description	
PCLN ^{R/L} ...-09	CN□G	0904..
PCLN ^{R/L} ...-12	CN□A CN□G CN□M	1204..
PCLN ^{R/L} ...-16		1606..
PCLN ^{R/L} ...-19		1906..

● Toolholder Dimensions

Description	Stock		Dimension (mm)						Std. Corner-R(RE)	Spare Parts						
	R	L	H	HF	B	LF	LH	WF		Lever	Lock Screw	Shim	Shim Pin	Punch	Wrench	
PCLN ^{R/L}	1616H-09	●	●	16	16	16	100	22	20	0.8	LL-1N	LS-1N	LC-32N	LSP-1	PC-1	FH-2.5
	2020K-09	●	●	20	20	20	125		25		LS-2N	LC-42N	LSP-2	PC-2	LW-3	
	2525M-09	●	●	25	25	25	150		32		LC-42N-20	*3LC-42N-C				
	2020H-12 ^{*1}	●		20	20	20	100	27	25	0.8	LL-2N	LS-2N	LC-53N	LSP-3	-	LW-3
	2020K-12	●	●													
	2525M-12	●	●	25	25	25	150	32	32	0.8	LL-5N	LS-4N	LC-63	LSP-4	-	LW-4
	3225P-12	●	●	32	32	25	170									
	2525M-16	●	●	25	25	25	150	32	32	0.8	LL-6	LS-5	LC-63	LSP-4	-	LW-4
	3232P-16	●	●	32	32	32	170									
3232P-19	●	●	32	32	32	170	40	40	1.6	LL-6	LS-5	LC-63	LSP-4	-	LW-4	

*1. Indicates short shank type

*2. When using inserts whose corner-R(RE) is greater than 1.6mm, please purchase a shim and use it in order to prevent workpiece and shim from interfering each other.

*3. When using the inserts with SX chipbreaker, prepare a shim separately.

● Applicable Inserts

Applications	Finishing	Finishing - Medium	Finishing	Finishing - Medium	Finishing - Medium	Finishing - Medium	Medium - Roughing	Medium - Roughing	Medium - Roughing
Insert	WF(Wiper)	WE(Wiper)	PP	PQ	CQ	CJ	GS	PG	PS
Size	12	12	12	12	12,16	12,16	09,12	12	12,16
Page	B16	B16	B16	B16	B17	B17	B17	B17	B17
Applications	Medium - Roughing / High Feed Rate	Roughing	Roughing	Single-sided / Roughing / High Feed Rate	Finishing	Medium	Soft Steel / Small ap	Soft Steel / Finishing	Soft Steel / Medium
Insert	PT	Standard	PH	PX	^{R/L} -S	^{R/L}	XF	XP	XQ
Size	12,16	12,16,19	12,16,19	12,16,19	09	09,12	12	12	12
Page	B18	B18	B18	B19	B22	B22	B19	B19	B19
Applications	Soft Steel / Roughing	Stainless Steel / Finishing	Stainless Steel / Medium-Roughing	Stainless Steel / Medium-Roughing	Cast Iron	Cast Iron	Cast Iron	Cast Iron	Cast Iron
Insert	XS	MQ	MS	MU	KQ	KG	KH	C	ZS
Size	12	12	12	12,16,19	12	12	12	12,16	12
Page	B19	B20	B20	B20	B21	B21	B21	B21	B21
Applications	Cast Iron	Cast Iron	Cast Iron	Non-ferrous Metals	Non-ferrous Metals	Non-ferrous Metals	Heat-resistant Alloys	Heat-resistant Alloys	Hard Materials
Insert	GC	Without Chipbreaker	Ceramic	A3	AH	PCD	SQ	^{R/L} -SX	CBN
Size	12	12	12	12	12	12	12,16,19	12,16,19	12
Page	B21	B21	B106	B22	B22	C23	B20	B21	C6, C7

Recommended Cutting Conditions ● D38~D39

● : Std. Item

Insert Grades
 Turnable Inserts
 CN & PCD Tools
 External
 Small Parts
 Machining
 Boring
 Grooving
 Cut-off
 Threading
 Drilling
 Milling
 Turning Mill
 Spare Parts
 Technical Information

A
 B
 C
 D
 E
 F
 G
 H
 J
 K
 M
 N
 P
 R
 T

Piping Parts for Coolant-through Holders

Easy Coolant Connections

Easy Connection with High Pressure Hose and Joint

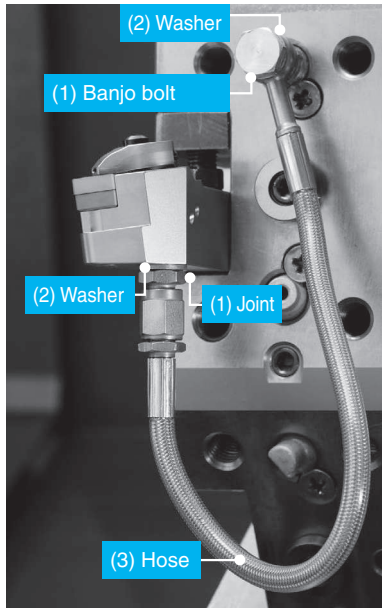

- Even without a high pressure pump, internal coolant can be used at a normal pressure.
- Banjo bolt available for angled hose connection. Can be used in a variety of machines.

D
External

<Piping Installation Guide>

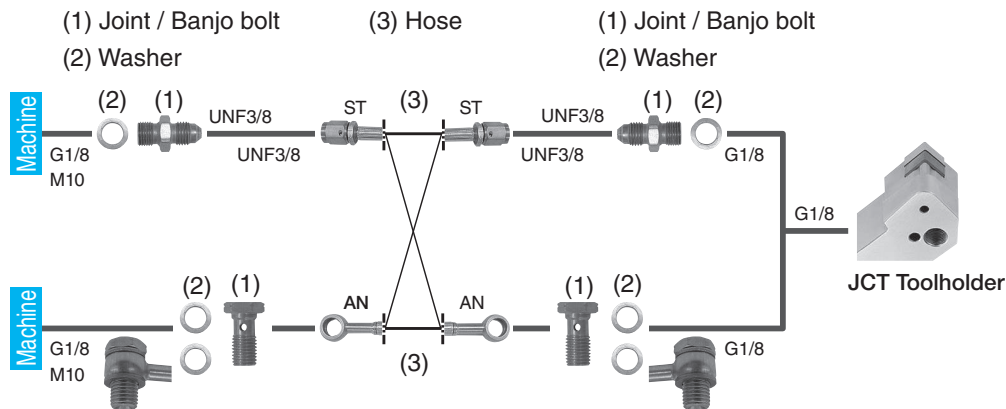

● Internal Coolant Benefits (Reference)

Coolant Pressure (MPa)	Tool Life	Chip Control	Remarks
~ 2 (Low Pressure)	○	-	Longer tool life under 1MPa
2 ~ 7 (Medium Pressure)	◎	○	Longer tool life and Improved chip control
7 ~ 15 (High Pressure)	◎	◎	Fine chip breaking
15 ~ 30 (Extra-high Pressure)	◎	◎	Fine chip breaking. High speed machining for heat-resistant alloys

Internal coolant under low pressure provides improved performance and stable machining

● Piping Parts



Optional Piping Parts Available (sold separately)

Choose among (1)(2)(3) based on the machine spec and piping configuration.

(1) Joint / Banjo bolt x 2 (2) Washer x 2-4 (3) Hose x 1

(1) Joint / Banjo bolt

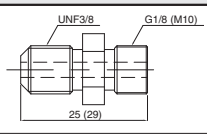
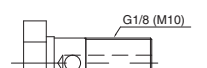
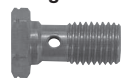
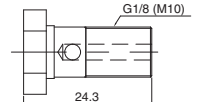
Pressure Resistance : ~30MPa

Shape	Description	Stock	Thread Standard	
			Thread connection to the machine	
		●	G1/8	
		●	M10X1.5	
Banjo bolt (for angled hose) 		●	G1/8	
		●	M10X1.5	

(2) Washer

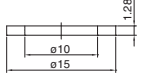

Pressure Resistance : ~30MPa

Shape	Description	Stock
 	WS-10	●

*Use 2 washers for a banjo bolt

(3) Hose

Pressure Resistance : ~30MPa

Shape	Description	Stock	Thread Standard		Dimension (mm)
					L
	HS-ST-ST-200	●	UNF3/8	UNF3/8	200
	HS-ST-ST-250	●			250
	HS-ST-AN-200	●	UNF3/8	-	(Banjo bolt)
	HS-ST-AN-250	●			
	HS-AN-AN-200	●	-	-	200
	HS-AN-AN-250	●			

Cautions

1. Make sure machine door is completely closed before use of these parts.
2. Use appropriate seal for the male thread of the piping parts and make sure the connection is secure.
Use plugs to seal off unused coolant holes.
3. Connect and fasten the coolant hose firmly.
4. The use of copper washers may cause leakage but will have no effect on the performance.
5. Commercial piping parts can be used if the thread standards are same. Check the pressure resistance before use.
6. Regularly changing the coolant filter is recommended.

● : Std. Item

Insert Grades
Turning
Indexable Inserts
CNC & PC Tools
External
Small Parts
Machining
Boring
Grooving
Cut-off
Threading
Drilling
Milling
Tools for
Spare Parts
Technical
Information
Index

A
B
C
D
E
F
G
H
J
K
M
N
P
R
T

External Turning Toolholders [DN□□ Insert]

DDJN (External / Copying)

Side Rake Angle : -6°
Angle of Inclination : -6°

● Applicable Inserts

Toolholder Description	Insert Description	
DDJN [°] /L...-1504	DN□A	1504.. (1506..)
	DN□G	
DDJN [°] /L...-1506	DN□M	1506.. (1504..)
	DNMX	

● Right-hand shown

DDJN -JCT (External / Copying / Coolant-through Holders)

Pressure Resistance : ~30MPa
Side Rake Angle : -6°
Angle of Inclination : -7°
Coolant supply: 3 directions

● Applicable Inserts

Toolholder Description	Insert Description	
DDJN [°] /L...-15JCT	DN□A	1504.. (1506..)
	DN□G	
	DN□M	
	DNMX	

● Right-hand shown

DDHN (External / Facing / Copying)

Side Rake Angle : -6°
Angle of Inclination : -6°

● Applicable Inserts

Toolholder Description	Insert Description	
DDHN [°] /L...-1504	DN□A	1504.. (1506..)
	DN□G	
DDHN [°] /L...-1506	DN□M	1506.. (1504..)

● Right-hand shown

● Toolholder Dimensions

Description	Stock		Dimension (mm)							Std. Corner-R(RE)	Spare Parts																									
	R	L	H	HF	B	LF	LH	WF	MHD		Clamp	Pipe Connection (**1 with O-ring)	Screw	Spring	Shim	Shim Screw	Wrench	Wrench																		
DDJN [°] /L 2020K -1504	●	●	20	20	20	125	39	25	-	0.8	CP-3D	-	CS-3D	SP-3D	SB-4085TR	-	FT-15	(For Shim sold separately)																		
2525M-1504	●	●	25	25	25	150		32											DD-44 (DD-43)																	
DDJN [°] /L 2020K -1506	●	●	20	20	20	125	25	-	CP-3D										-	CS-3D	SP-3D	SB-4085TR	-	FT-15	(For Shim sold separately)											
2525M-1506	●	●	25	25	25	150	32																			DD-43 (**2DD-44)										
DDJN [°] /L 2020K -15JCT	●	●	20	20	20	125	37	25																		101	0.8	CP-4D [°] /L-JCT	FP-12	CS-3D-TR	SP-3D	SB-4085TR	-	FT-15	(For Shim sold separately)	
2525M-15JCT	●	●	25	25	25	150		32																		126										DD-44 (DD-43)
DDHN [°] /L 2020K -1504	●	●	20	20	20	125	37	25		-	0.8	CP-3D	-	CS-3D	SP-3D	SB-4085TR	-	FT-15								(For Shim sold separately)										
2525M-1504	●	●	25	25	25	150		32																												DD-44 (DD-43)
DDHN [°] /L 2020K -1506	●	●	20	20	20	125	37	25	-	0.8									CP-3D	-	CS-3D	SP-3D	SB-4085TR	-	FT-15											(For Shim sold separately)
2525M-1506	●	●	25	25	25	150		32																												

Please see page D10 and D11 for piping parts of coolant-through holders.

Shims indicated within brackets () are not included with the toolholder. To change insert thickness, please purchase it separately.

*1 It is possible to order just an O-ring (SS-035).

*2. When using inserts whose corner-R(RE) is greater than 1.6mm, additional modifications to the shim are necessary in order to prevent workpiece and shim from interfering each other.

· Recommended tightening torque 3.9N·m

● : Std. Item

PDJN (External / Copying)

Side Rake Angle : -6°
Angle of Inclination : -7°

● Applicable Inserts

Toolholder Description	Insert Description	
PDJN ^{°/L}-11	DN□A DN□G	1104..
PDJN ^{°/L}-15	DN□A DN□G	1504..
PDJN ^{°/L}-15U	DN□M DNMX	1506.. (1504..)

● Right-hand shown

PDHN (External / Facing / Copying)

Side Rake Angle : -6°
Angle of Inclination : -6°

● Applicable Inserts

Toolholder Description	Insert Description	
PDHN ^{°/L}-15	DN□A DN□G DN□M	1504.. (1506..)

● Right-hand shown

● Toolholder Dimensions

Description	Stock		Dimension (mm)						Std. Corner-R(RE)	Spare Parts						
	R	L	H	HF	B	LF	LH	WF		Lever	Lock Screw	Shim	Shim Pin	Punch	Wrench	
PDJN ^{°/L}	1616H -11	●	●	16	16	16	100		20	0.4	LL-1DN	LS-1N	LD-32N	LSP-1	PC-1	FH-2.5
	2020K -11	●	●	20	20	20	125	28	25							
	2525M -11	●	●	25	25	25	150		32							
	2020H -15*1	●	●	20	20	20	100		25							
	2020K -15	●	●	20	20	20	125	36	25							
	2525M -15	●	●	25	25	25	150		32							
	3225P -15	●	●	32	32	25	170		32							
	2525M -15U	●	●	25	25	25	150	34	32							
3232P -15U	●	●	32	32	32	170	36	40	0.8	LL-4	LS-3	LD-42 *LD-42-20 (LD-43) (*LD-43-20)	LSP-2	PC-2	LW-3	
PDHN ^{°/L}	2020K -15	●	●	20	20	20	125	35								25
	2525M -15	●	●	25	25	25	150	34	32							

*1. Indicates short shank type
 · Shim : PDJN^{°/L}-15U ...LD-42 is attached to PDJN^{°/L}-15U. When using DN□□1504 type insert, please purchase LD-43 separately.
 PDHN ...LD-43 is attached to PDHN. When using DN□□1506 type Insert, please purchase LD-42 separately.
 · When using inserts whose corner-R(RE) is greater than 1.6mm, please purchase a shim*2 and use it in order to prevent workpiece and shim from interfering each other.

● Applicable Inserts

Applications	* Finishing	Finishing	Finishing - Medium	Finishing - Medium	Finishing - Medium	Medium - Roughing	Medium - Roughing	Medium - Roughing	Medium - Roughing / High Feed Rate	Roughing	Roughing
Insert	WF(Wiper)	PP	PQ	CQ	CJ	GS	PG	PS	PT	Standard	PH
Size	1504,1506	1504,1506	1504,1506	1504,1506	1504,1506	1104,1504,1506	1504,1506	1504,1506	1504,1506	1504,1506	1504,1506
Page	B23	B23	B23	B24	B24	B24	B25	B25	B25	B26	B26
Applications	Single-sided / Roughing / High Feed Rate	Finishing	Medium	Soft Steel / Finishing	Soft Steel / Medium	Soft Steel / Roughing	Stainless Steel / Finishing	Stainless Steel / Medium-Roughing	Stainless Steel / Medium-Roughing	Stainless Steel / Medium-Roughing	Cast Iron
Insert	PX	°/L-S	°/L	XP	XQ	XS	MQ	MS	MU	TK	C
Size	1504,1506	1104	1104,1504	1504,1506	1504	1504	1504,1506	1504,1506	1504,1506	1504,1506	1504,1506
Page	B26	B30	B30	B26	B26	B26	B27	B28	B28	B27	B29
Applications	Cast Iron	Cast Iron	Cast Iron	Cast Iron	Cast Iron	Cast Iron	Non-ferrous Metals	Non-ferrous Metals	Non-ferrous Metals	Heat-resistant Alloys	Hard Materials
Insert	KQ	KG	KH	ZS	GC	Ceramic	°/L-A3	AH	PCD	SQ	CBN
Size	1504,1506	1504,1506	1504,1506	1504,1506	1504,1506	1504,1506	1504	1504,1506	1504	1504,1506	1504,1506
Page	B29	B29	B29	B29	B29	B107	B30	B30	C23	B28	C8, C9

* When using the insert with WF chipbreaker, tool edge offset or program corrections are required. ● R35
 The insert with WF chipbreaker is not applicable for DDHN type and PDHN type toolholder.

● : Std. Item

Recommended Cutting Conditions ● D38~D39

DSBN (External)

• Right-hand shown

2020K-12 type

Side Rake Angle : -4°
Angle of Inclination : -7°

● Applicable Inserts

Toolholder Description	Insert Description	
DSBN ^{R/L} ...-12	SN□A SN□G SN□M	1204..

● Toolholder Dimensions

Description	Stock		Dimension (mm)						Std. Corner-R(RE)	Spare Parts						
	R	L	H	HF	B	LF	LH	WF		Clamp	Screw	Spring	Shim	Shim Screw	Wrench	Wrench (sold separately)
DSBN ^{R/L} 2020K -12	●	●	20	20	20	125	34	17	0.8							
	●	●	25	25	25	150		22								

• Recommended tightening torque 3.9N·m

PSBN (External)

• Right-hand shown

Side Rake Angle : -4°
Angle of Inclination : -7°

PSKN (Facing)

• Right-hand shown

Side Rake Angle : -4°
Angle of Inclination : -7°

● Toolholder Dimensions

Description	Stock		Dimension (mm)						Std. Corner-R(RE)	Spare Parts											
	R	L	H	HF	B	LF	LH	WF		Lever	Lock Screw	Shim	Shim Pin	Punch	Wrench						
PSBN ^{R/L}	●	●	16	16	16	100	21	13	0.8												
	●	●	20	20	20	125	27	17								LL-1N	LS-1N	LS-32	LSP-1	PC-1	FH-2.5
	●	●	25	25	25	150	24	22								LL-2N	LS-2N	LS-42	LSP-2	PC-2	LW-3
PSKN ^{R/L}	●	●	16	16	16	100	19	20	0.8												
	●	●	20	20	20	125	22.5	25								LL-1N	LS-1N	LS-32	LSP-1	PC-1	FH-2.5
	●	●	25	25	25	150		32								LL-2N	LS-2N	LS-42	LSP-2	PC-2	LW-3

• PSKN^{R/L} : Left-hand Insert for Right-hand Toolholder,
Right-hand Insert for Left-hand Toolholder.

• When using inserts whose corner-R(RE) is greater than 1.6 mm, additional modifications to the shim are necessary in order to prevent workpiece and shim from interfering each other.

● : Std. Item

PSSN (External / Facing / Chamfering)

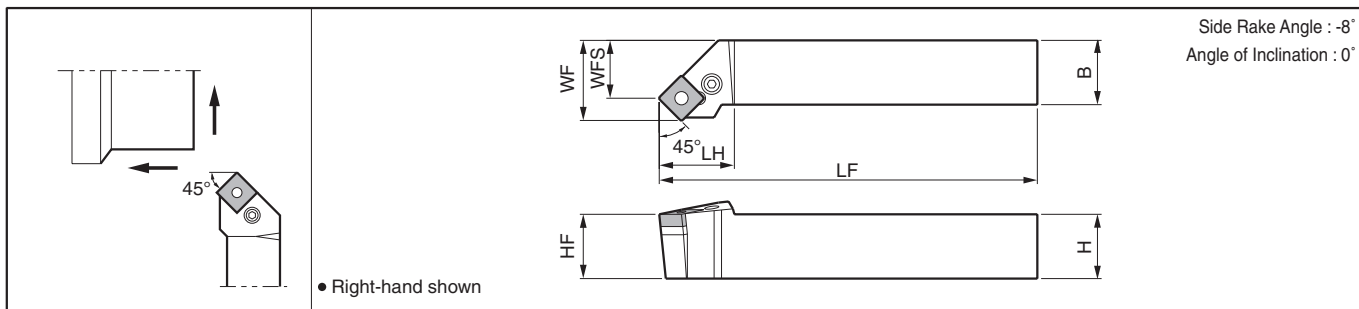

PSDN (External / Chamfering)

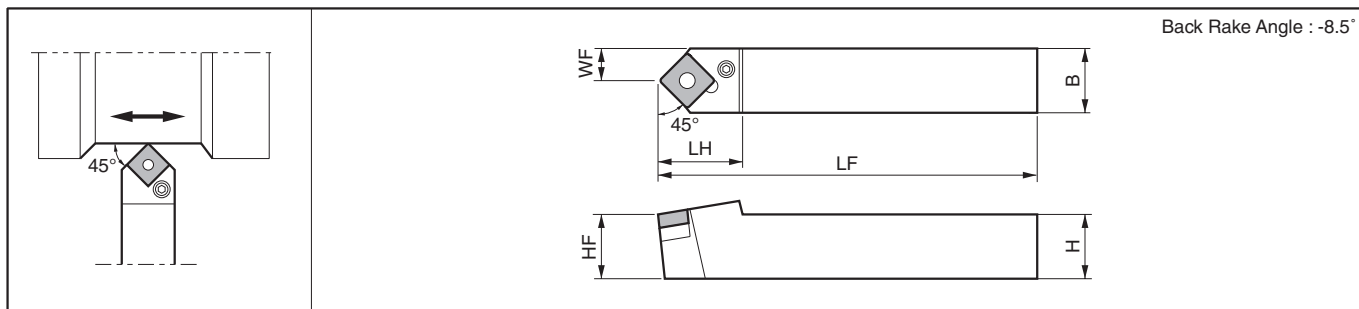

● Toolholder Dimensions

Description	Stock		Dimension (mm)								Std. Corner-R(RE)	Spare Parts					
	R	N	L	H	HF	B	LF	LH	WF	WFS		Lever	Lock Screw	Shim	Shim Pin	Punch	Wrench
PSSN ^{F/L}	1616H-09	●	●	16	16	16	100	22	20	13.6	0.8	LL-1N	LS-1N	LS-32	LSP-1	PC-1	FH-2.5
	2020K-12	●	●	20	20	20	125	29	25	16.4	0.8	LL-2N	LS-2N	LS-42	LSP-2	PC-2	LW-3
	2525M-12	●	●	25	25	25	150	32	23.4	0.8	LL-2N	LS-2N	LS-42	LSP-2	PC-2	LW-3	
PSDNN	1616H-09	●		16	16	16	100	21	8	-	0.8	LL-1N	LS-1N	LS-32	LSP-1	PC-1	FH-2.5
	2020K-12	●		20	20	20	125	30	10	-	0.8	LL-2N	LS-2N	LS-42	LSP-2	PC-2	LW-3
	2525M-12	●		25	25	25	150	30	12.5	-	0.8	LL-2N	LS-2N	LS-42	LSP-2	PC-2	LW-3

When using inserts whose corner-R(RE) is greater than 1.6 mm, additional modifications to the shim are necessary in order to prevent workpiece and shim from interfering each other.

● Applicable Inserts

Toolholder Description	Insert Description		Applications	Finishing - Medium	Medium - Roughing	Medium - Roughing	Medium - Roughing / High Feed Rate	Roughing	Roughing	Single-sided / Roughing / High Feed Rate	Finishing - Roughing	
PSBN ^{F/L} ...-09	SN□G	0903..	Insert									
PSKN ^{F/L} ...-09				12	12	12	12	09, 12	12	12	09, 12	
PSSN ^{F/L} ...-09				Page	B32	B32	B32	B32	B32	B33	B33	B35
PSDNN...-09	SN□A SN□G SN□M	1204..	Insert									
PSBN ^{F/L} ...-12				Applications	Medium-Roughing / Low Cutting Force	Soft Steel / Finishing	Soft Steel / Medium	Soft Steel / Roughing	Stainless Steel / Finishing	Stainless Steel / Medium-Roughing	Cast Iron	Cast Iron
PSKN ^{F/L} ...-12				Size	12	12	12	12	12	12	12	12
PSSN ^{F/L} ...-12												
PSDNN...-12				Applications	Cast Iron	Cast Iron	Cast Iron	Cast Iron	Cast Iron	Hard Materials		
				Size	12	12	12	12	12	12		
				Page	B34	B34	B34	B35	B109	C10		

● PSSN^{F/L} : When using handed inserts,
For External Turning, Right-hand Insert for Right-hand Toolholder,
Left-hand Insert for Left-hand Toolholder.
For Facing, Left-hand Insert for Right-hand Toolholder,
Right-hand Insert for Left-hand Toolholder.

Recommended Cutting Conditions
● D38~D39

External Turning Toolholders [TN□□ Insert]

DTGN (External)

• Right-hand shown

Side Rake Angle : -6°
Angle of Inclination : -6°

● Applicable Inserts

Toolholder Description	Insert Description
DTGN ^{R/L} ...-16	TN□A
	TN□G
	TN□M
	TNM X

● Toolholder Dimensions

Description	Stock		Dimension (mm)							Std. Corner-R(RE)	Spare Parts						
	R	L	H	HF	B	LF	LH	WF	Clamp		Screw	Spring	Shim	Shim Screw	Wrench	Wrench (sold separately)	
DTGN ^{R/L} 2020K -16	●	●	20	20	20	125	25	25	0.8	CP-2D	CS-2D	SP-2D	*DT-32	SB-3080TR	LW-2.5	FT-10	
	2525M -16	●	●	25	25	25											150

- When using inserts whose corner-R(RE) is greater than 1.6mm, additional modifications to the shim are necessary in order to prevent workpiece and shim from interfering each other.
- When using the insert with WF chipbreaker (wiper insert), tool edge offset or program corrections are required. ● R35
- Recommended tightening torque 1.7N·m

DTGN-JCT (External / Coolant-through Holders) NEW

Pressure Resistance : ~ 30MPa

• Right-hand shown

2020K-16JCT

Side Rake Angle : -6°
Angle of Inclination : -6°
Coolant supply: 2 directions

● Applicable Inserts

Toolholder Description	Insert Description
DTGN ^{R/L} ...-16JCT	TN□A
	TN□G
	TN□M
	TNM X

● Toolholder Dimensions

Description	Stock		Dimension (mm)							Std. Corner-R(RE)	Spare Parts							
	R	L	H	HF	B	LF	LH	WF	MHD		Clamp	Pipe Connection (with O-ring)	Screw	Spring	Shim	Shim Screw	Wrench	Wrench (sold separately)
DTGN ^{R/L} 2020K-16JCT	●	●	20	20	20	125	27	25	104	0.8	CP-2D- ^{R/L} JCT	FP-12	CS-3D-TR	SP-3D	DT-32	SB-3080TR	FT-15	FT-10
	2525M-16JCT	●	●	25	25	25												

- When using inserts whose corner-R(RE) is greater than 1.6mm, additional modifications to the shim are necessary in order to prevent workpiece and shim from interfering each other.
- When using the insert with WF chipbreaker (wiper insert), tool edge offset or program corrections are required. ● R35
- Please see page D10 and D11 for piping parts of coolant-through holders.
- O-ring (SS-035) is available to order.
- Recommended tightening torque 3.9N·m

● : Std. Item

PTGN (External)

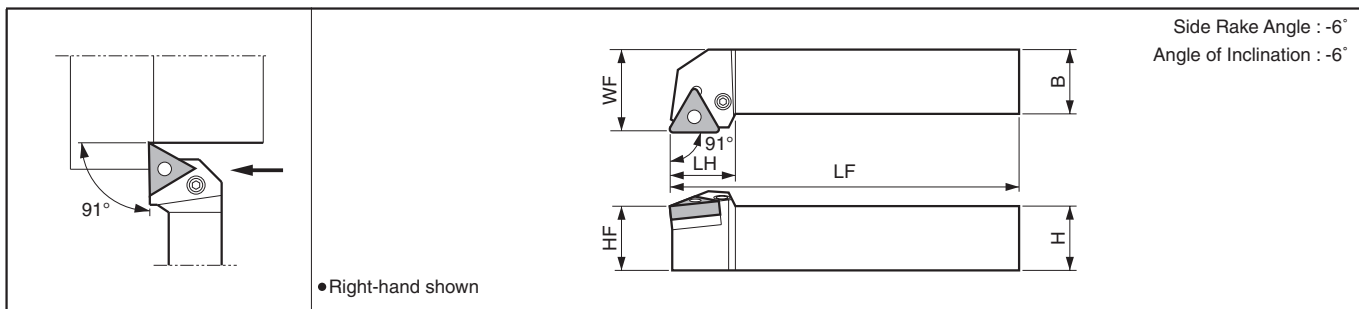

PTFN (Facing)

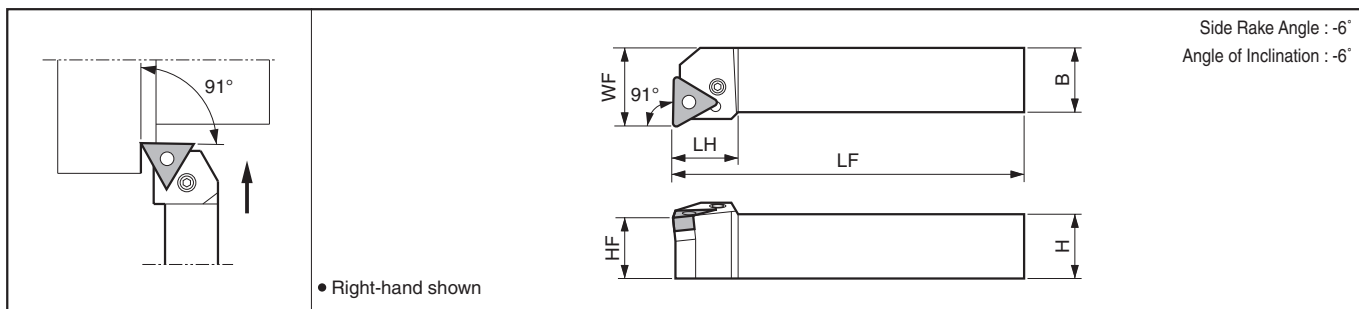

Toolholder Dimensions

Description	Stock		Dimension (mm)							Std. Corner-R(RE)	Spare Parts					
	R	L	H	HF	B	LF	LH	WF	Lever		Lock Screw	Shim	Shim Pin	Punch	Wrench	
PTGN ^{9/16}	1212F -11	●●	12	12	12	80	18	16	0.8	LL-03N	LS-03N	-	P-03	-	FH-2	
	1616H -11	●●	16	16	16	100		20								
	2020K -11	●●	20	20	20	125	22	25	0.8	LL-03TN	LS-03SN	-	P-03S	-	FH-2.5	
	2525M -11	●●	25	25	25	150		32								
	1616H -16	●●	16	16	16			20								
	2020H -16*1	●														
	2020K -16	●●	20	20	20	125	24	25	0.8	LL-1N	LS-1N	LT-32N *2LT-32N-20	LSP-1	PC-1	FH-2.5	
	2525M -16	●●	25	25	25	150		32								
	2525M -22	●●	25	25	25	150	29	32	0.8	LL-2N	LS-2N	LT-42N *2LT-42N-20	LSP-2	PC-2	LW-3	
PTFN ^{9/16}	1212F -11	●●	12	12	12	80	15	16	0.8	LL-03N	LS-03N	-	P-03	-	FH-2	
	1616H -11	●●	16	16	16	100		20								
	2020K -11	●●	20	20	20	125	22.5	25	0.8	LL-03TN	LS-03SN	-	P-03S	-	FH-2.5	
	2525M -11	●●	25	25	25	150		32								
	2020K -16	●●	20	20	20	125	22	25	0.8	LL-1N	LS-1N	LT-32N *2LT-32N-20	LSP-1	PC-1	FH-2.5	
	2525M -16	●●	25	25	25	150	23	32								
	2525M -22	●●	25	25	25	150	28	32	0.8	LL-2N	LS-2N	LT-42N *2LT-42N-20	LSP-2	PC-2	LW-3	

*1. Indicates short shank type
 · When using inserts whose corner-R(RE) is greater than 1.6mm, please purchase a shim*2 and use it in order to prevent workpiece and shim from interfering each other.
 · When using the insert with WF chipbreaker (wiper insert), tool edge offset or program corrections are required. ● R35

Applicable Inserts

Toolholder Description	Insert Description	Toolholder Description	Insert Description
PT□N ^{9/16} 12...-11	1103..	PT□N ^{9/16} ...-16	TN□A TN□G 1604..
PT□N ^{9/16} ...-11	1104..	PT□N ^{9/16} ...-22	TN□M *3TNMX 2204..

PTGN^{9/16} 1212F-11 }
 PTFN^{9/16} 1212F-11 } Insert applicable for above TN□□1103 type Insert is applicable.

*3. TNMX type insert is not applicable for PT□N^{9/16}...-22 toolholder.

· PTFN^{9/16} : Left-hand Insert for Right-hand Toolholder,
 Right-hand Insert for Left-hand Toolholder.

WTJN-N (External / Copying)

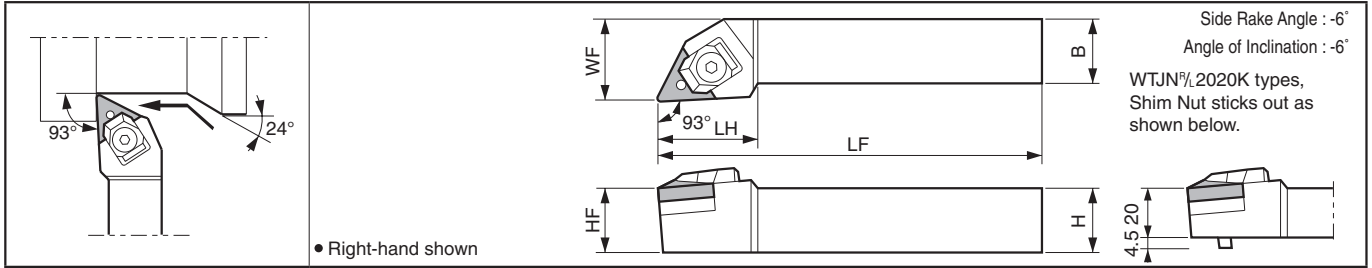

WTKN-N (External / Facing / Copying)

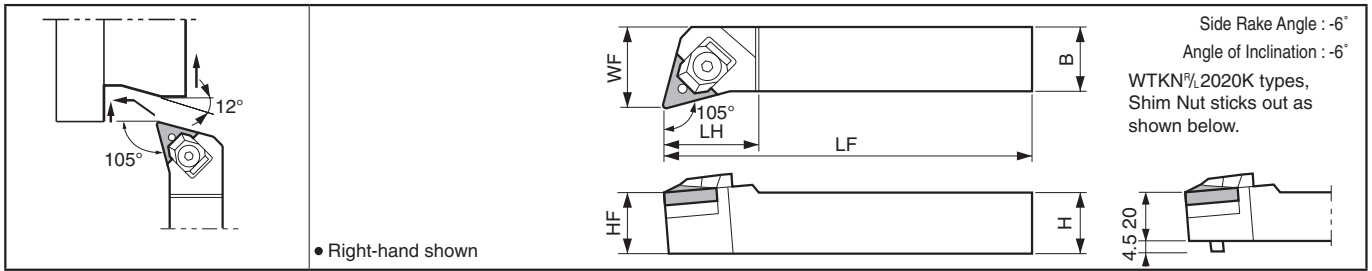

WTEN-N (External / Chamfering)

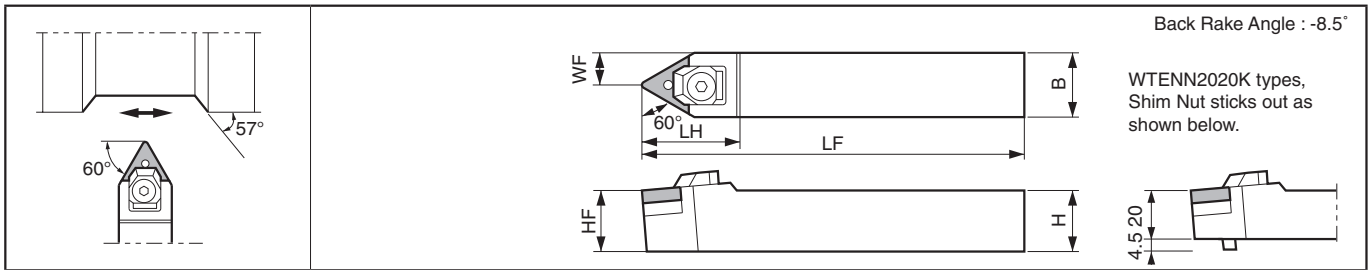

Toolholder Dimensions

Description	Stock			Dimension (mm)						Std. Corner-R(RE)	Spare Parts					
	R	N	L	H	HF	B	LF	LH	WF		Clamp Set	Shim	Shim Pin	Shim Nut	Wrench	Spacer
WTJN ^{3/4} 2020K-16N	●	●	20	20	20	20	125	32	25	0.8	WCS-1N	WTN-33 *WTN -33-20	WP-1S	WN-1	LW-3	WSP-1
2525M-16N	●	●	25	25	25	150	32	32								
WTKN ^{3/4} 2020K-16N	●	●	20	20	20	125	32	25								
2525M-16N	●	●	25	25	25	150	32	32								
WTENN 2020K-16N	●	●	20	20	20	125	32	10	12.5							
2525M-16N	●	●	25	25	25	150	32	12.5								

When using inserts whose corner-R(RE) is greater than 1.6mm, please purchase a shim (WTN-33-20) with * mark and use it in order to prevent workpiece and shim from interfering with each other.

Applicable Inserts

Toolholder Description	Insert Description	Applications	Finishing	Finishing - Medium	Finishing - Medium	Medium - Roughing	Medium - Roughing	Medium - Roughing	Medium - Roughing / High Feed Rate	Medium - Roughing / High Feed Rate	Roughing			
WTJN ^{3/4} ...-16N	TN□A TN□G TN□M 1604..	Insert	PP	PQ	CQ	GS	PG	PS	PT	GT	PH			
WTKN ^{3/4} ...-16N		Size	16	16	16,22	1104,16	16	16,22	16	16	16,22			
WTENN ...-16N		Page	B36	B36	B36	B36	B36	B37	B37	B37	B37			
		Applications	Single-sided / Roughing / High Feed Rate	Roughing	Finishing	Finishing - Roughing	Medium-Roughing / Low Cutting Force	Soft Steel / Small ap	Soft Steel / Finishing	Soft Steel / Medium	Soft Steel / Roughing			
		Insert	PX	Standard	3/4-S	3/4-□	3/4-25R	XF	XP	XQ	XS			
		Size	16,22	16,22	1104,16	1103,1104,16,22	16	16	16	16	16			
		Page	B38	B37	B42	B42,B43	B43	B38	B38	B38	B38			
		Applications	Stainless Steel / Finishing	Stainless Steel / Medium-Roughing	Stainless Steel / Medium-Roughing	Cast Iron	Cast Iron	Cast Iron	Cast Iron	Cast Iron	Non-ferrous Metals	Non-ferrous Metals	Non-ferrous Metals	Hard Materials
		Insert	MQ	MS	MU	KQ	KG	KH	ZS	Ceramic	3/4-A3	AH	PCD	CBN
		Size	16	16	16	16	16	16	16	16	16	16	16	16
		Page	B39	B39	B39	B40	B40	B40	B40	B111	B41	B41	C23	C11

In wedge lock, use of ceramic insert other than silicon nitride insert is not recommended due to strong restrain force.

Recommended Cutting Conditions **D38~D39**

● : Std. Item

External Turning Toolholders [VN□□ Insert]

Insert Grades
Turning
Indexable Inserts
CNC & PCO Tools
External
Small Parts
Machining
Boring
Grooving
Cut-off
Threading
Drilling
Milling
Tools for Mill
Spare Parts
Technical Information
Index

A
B
C
D
E
F
G
H
J
K
M
N
P
R
T

DVLN (External / Copying)

Side Rake Angle : -6°
Angle of Inclination : -9°

● Applicable Inserts

Toolholder Description	Insert Description	
DVLN ^{F/L} ...-16	VN□A VN□G VN□M	1604..

● Right-hand shown

DVPN (External / Facing / Copying / Undercutting)

Side Rake Angle : -13°
Angle of Inclination : -10°

● Applicable Inserts

Toolholder Description	Insert Description	
DVPN ^{F/L} ...-16	VN□A VN□G VN□M	1604..

● Right-hand shown

DVVN (External / Copying)

Back Rake Angle : -11°

● Applicable Inserts

Toolholder Description	Insert Description	
DVVNN...-16	VN□A VN□G VN□M	1604..

● Toolholder Dimensions

Description	Stock			Dimension (mm)						Std. Corner-R(RE)	Spare Parts						
	R	N	L	H	HF	B	LF	LH	WF		Clamp	Screw	Spring	Shim	Shim Screw	Wrench	Wrench (sold separately)
DVLN ^{F/L}	2020K-16	●	●	20	20	20	125	45	25	0.8	CP-5D	CS-5D	SP-5D	DV-33	SB-4085TR	LW-3	FT-15
	2525M-16	●	●	25	25	25	150		32								
DVPN ^{F/L}	2020K-16	●	●	20	20	20	125	40	27								
	2525M-16	●	●	25	25	25	150		32								
DVVNN	2020K-16		●	20	20	20	125	46	10								
	2525M-16		●	25	25	25	150		12.5								

· When using inserts whose corner-R(RE) is greater than 1.2 mm, additional modifications to the shim are necessary in order to prevent workpiece and shim from interfering each other.
· Recommended tightening torque 3.0N·m

DVLN -JCT (External / Copying / Coolant-through Holders) NEW

Pressure Resistance : ~30MPa

Ramping depth : Less than 20mm

Ramping depth : 20mm or more

• Right-hand shown

Side Rake Angle : -6°
Angle of Inclination : -9°
Coolant supply: 2 directions

2020K-16JCT

● Applicable Inserts

Toolholder Description	Insert Description
DVLN %/L...-16JCT	VN□A VN□G VN□M 1604..

DVPN -JCT (External / Facing / Copying / Undercutting / Coolant-through Holders) NEW

Pressure Resistance : ~30MPa

• Right-hand shown

2020K-16JCT

Side Rake Angle : -13°
Angle of Inclination : -10°
Coolant supply: 2 directions

● Applicable Inserts

Toolholder Description	Insert Description
DVPN %/L...-16JCT	VN□A VN□G VN□M 1604..

DVNN -JCT (External / Copying / Coolant-through Holders) NEW

Pressure Resistance : ~30MPa

• Right-hand shown

2020K-16JCT

Back Rake Angle : -11°
Coolant supply: 1 direction

● Applicable Inserts

Toolholder Description	Insert Description
DVNN...-16JCT	VN□A VN□G VN□M 1604..

● Toolholder Dimensions

Description	Stock			Dimension (mm)							Std. Corner-R(RE)	Spare Parts						
	R	N	L	H	HF	B	LF	LH	WF	MHD		Clamp	Pipe Connection (with C-ring)	Screw	Spring	Shim	Shim Screw	Wrench
DVLNR 2020K-16JCT	●			20	20	20	125	45	25	92.5	0.8	CP-5D-JCT	FP-12	CS-3D-TR	SP-3D	DV-33	SB-4085TR	FT-15
2525M-16JCT	●			25	25	25	150		32	117.5								
DVLNL 2020K-16JCT		●		20	20	20	125	40	25	88.5								
2525M-16JCT		●		25	25	25	150		32	113.5								
DVPCR 2020K-16JCT	●			20	20	20	125	48	25	101.5								
2525M-16JCT	●			25	25	25	150		32	126.5								
DVPNL 2020K-16JCT		●		20	20	20	125	48	25	93.5								
2525M-16JCT		●		25	25	25	150		32	118.5								
DVVNN 2020K-16JCT		●		20	20	20	125	48	10	87.0								
2525M-16JCT		●		25	25	25	150		12.5	112.0								

- When using inserts whose corner-R(RE) is greater than 1.2 mm, additional modifications to the shim are necessary in order to prevent workpiece and shim from interfering each other.
- The washer may protrude from the holder. To prevent interference, additional modifications to the washer may be required.
- O-ring (SS-035) is available to order.
- Please see page D10 and D11 for piping parts of coolant-through holders.
- Recommended tightening torque 3.9N·m

● : Std. Item

MVLN (External / Copying)

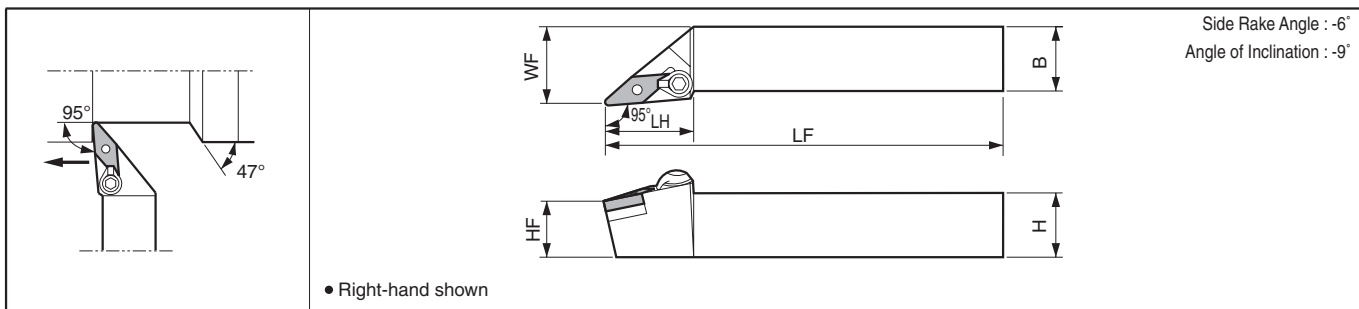

MVVN (External / Copying)

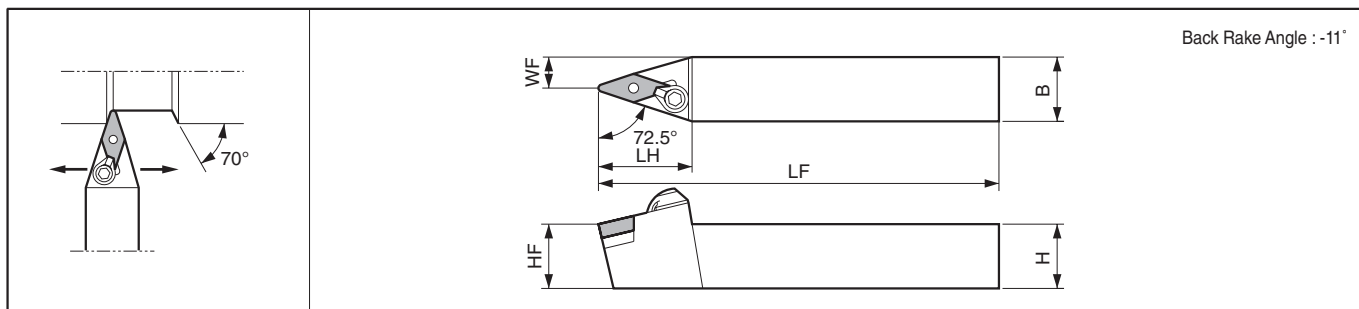

● Toolholder Dimensions

Description	Stock			Dimension (mm)						Std. Corner-R(RE)	Spare Parts				
	R	N	L	H	HF	B	LF	LH	WF		Clamp Set	Wrench	Shim	Lock Pin	Wrench
MVLN^{R/L} 2020K -16 2525M -16	●		●	20	20	20	125	38	25	0.8					
	●		●	25	25	25	150		32						
MVVNN 2020K -16 2525M -16			●	20	20	20	125	39	10	0.8					
			●	25	25	25	150		12.5						

• Clamp Set : CPS-5R for Right-hand Toolholder, CPS-5L for Left-hand Toolholder.

• When using inserts whose corner-R(RE) is greater than 1.2 mm, additional modifications to the shim are necessary in order to prevent workpiece and shim from interfering each other.

● Applicable Inserts

Toolholder Description	Insert Description	Applications	Finishing	Finishing - Medium	Finishing - Medium	Finishing - Medium	Medium	Roughing	Finishing - Medium	Stainless Steel / Finishing	
MVLN^{R/L}...-16 MVVNN...-16	VN□A VN□G VN□M 1604..	Insert	PP	^{R/L} -VC	VF	PQ	TN-V	Standard	^{R/L}	MQ	
		Size	16	16	16	16	16	16	16	16	
		Page	B44	B44	B44	B44	B44	B44	B44	B45	B45
		Applications	Stainless Steel / Medium-Roughing	Stainless Steel / Medium-Roughing	Cast Iron	Cast Iron	Cast Iron	Cast Iron	Non-ferrous Metals	Hard Materials	
		Insert	MS	MU	KG	KH	Without Chipbreaker	Ceramic	PCD	CBN	
		Size	16	16	16	16	16	16	16	16	
		Page	B45	B45	B45	B45	B45	B45	B112	C23	C12

◆ Regarding rotation directions of the clamp set

Recommended Cutting Conditions ◆ D38~D39

MVVNN type (Neutral)
MVLNR type (Right-hand Toolholder)

Clamp set : (CPS-5R) has Right-hand thread.
When clamping the insert, turn the screw in the arrow direction (clockwise).
When removing the insert, turn the screw away from the arrow (counterclockwise).

MVLNL type (Left-hand Toolholder)

Clamp set : (CPS-5L) has Left-hand thread.
When clamping the insert, turn the screw in the arrow direction (counterclockwise).
When removing the insert, turn the screw away from the arrow (clockwise).

● : Std. Item

PVLN (External / Copying)

Side Rake Angle : -6°
Angle of Inclination : -9°

• Right-hand shown

PVPN (External / Facing / Copying / Undercutting)

Side Rake Angle : -13°
Angle of Inclination : -10°

• Right-hand shown

PVVN (External / Copying)

Back Rake Angle : -11°

Toolholder Dimensions

Description	Stock			Dimension (mm)						Std. Corner-R(RE)	Spare Parts			
	R	N	L	H	HF	B	LF	LH	WF		Lock Pin	Lock Screw	Shim	Wrench
	PVLN^{β/L} 2525M-16Q	●	●	25	25	25	150	37	32		0.8			
PVPN^{β/L} 2020K-16Q	●	●	20	20	20	125	30	25	0.8					
2525M-16Q	●	●	25	25	25	150	40	12.5	0.8					
PVVNN 2020K-16Q		●	20	20	20	125	35	10	0.8					
2525M-16Q		●	25	25	25	150	40	12.5	0.8					

When using inserts whose corner-R(RE) is greater than 1.2 mm, additional modifications to the shim are necessary in order to prevent workpiece and shim from interfering each other.

Applicable Inserts

Toolholder Description	Insert Description	Applications	Finishing	Finishing - Medium	Finishing - Medium	Finishing - Medium	Medium	Roughing	Finishing - Medium	Stainless Steel / Finishing	
PVLN^{β/L}...-16Q	VN□A	Insert									
PVPN^{β/L}...-16Q	VN□G		1604..								
PVVNN...-16Q	VN□M		Stainless Steel / Medium-Roughing	Stainless Steel / Medium-Roughing	Cast Iron	Cast Iron	Cast Iron	Cast Iron	Non-ferrous Metals	Hard Materials	
Size		16	16	16	16	16	16	16	16	16	
Page		B44	B44	B44	B44	B44	B44	B44	B45	B45	
Size		16	16	16	16	16	16	16	16	16	
Page		B45	B45	B45	B45	B45	B45	B112	C23	C12	

Recommended Cutting Conditions **D38~D39**

● : Std. Item

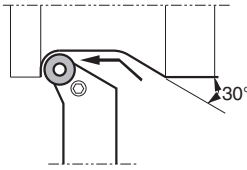
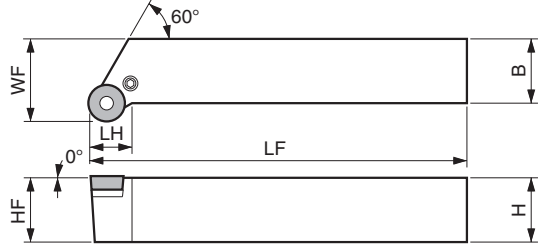
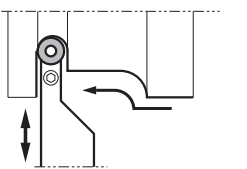
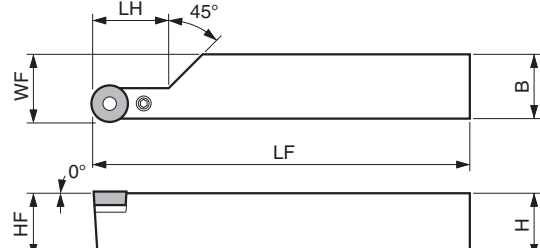
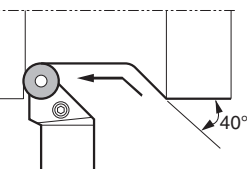
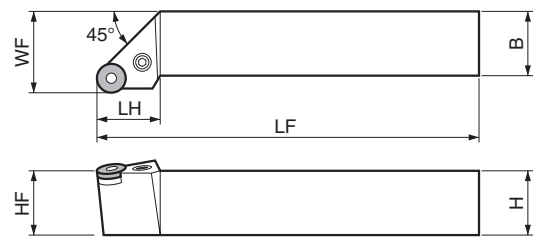

PRGC / PRXC / PRGN (External / Facing / Copying)

<p>PRGC</p>  <p>• Right-hand shown</p>	 <p>Side Rake Angle : 0° Angle of Inclination : 0°</p>
<p>PRXC</p>  <p>• Right-hand shown</p>	 <p>Side Rake Angle : 0° Angle of Inclination : 0°</p>
<p>PRGN</p>  <p>• Right-hand shown</p>	 <p>Side Rake Angle : -6° Angle of Inclination : -6°</p>

Toolholder Dimensions

Description	Stock		Dimension (mm)						Std. Corner-R(RE)	Spare Parts						
	R	L	H	HF	B	LF	LH	WF		Lever	Lock Screw	Shim	Shim Pin	Punch	Wrench	
																
PRGC ^{R/L}	2020K -10	●	●	20	20	20	125	15	25	-	LL-05C	LS-05	LR-10C	LSP-1	PC-1	FH-2
	2525M -10	●	●	25	25	25	150	17	32	-	LL-1CN	LS-1N	LR-12C	LSP-1	PC-1	FH-2.5
	2020K -12	●	●	20	20	20	125	14	25	-	LL-05C	LS-05	LR-10C	LSP-1	PC-1	FH-2
	2525M -12	●	●	25	25	25	150	17	32	-	LL-1CN	LS-1N	LR-12C	LSP-1	PC-1	FH-2.5
PRXC ^{R/L}	2020K -10	●	●	20	20	20	125	25	20.5	-	LL-05C	LS-05	LR-10C	LSP-1	PC-1	FH-2
	2525M -10	●	●	25	25	25	150	30	25.5	-	LL-05C	LS-05	LR-10C	LSP-1	PC-1	FH-2
	2525Q -10	●	●	25	25	25	180	30	25.5	-	LL-05C	LS-05	LR-10C	LSP-1	PC-1	FH-2
	2525M -12	●	●	25	25	25	150	30	25.7	-	LL-1CN	LS-1N	LR-12C	LSP-1	PC-1	FH-2.5
PRGN ^{R/L}	2020K -09	●	●	20	20	20	125	19	25	-	LL-1N	LS-1N	LR-80	LSP-1	PC-1	FH-2.5
	2525M -12	●	●	25	25	25	150	26	32	-	LL-2N	LS-2N	LR-81	LSP-2	PC-2	LW-3

Applicable Inserts

Toolholder Description	Insert Description	Applications	Medium	Non-ferrous Metals								
PRGC ^{R/L} ...-10	RCGX RCMX	Insert	Standard	AQ								
PRGC ^{R/L} ...-12			1003M0									
PRXC ^{R/L} ...-10			1204M0	Size	10, 12	10						
PRXC ^{R/L} ...-12			1003M0	Page	B74	B74						
PRGN ^{R/L} ...-09	RNMG	Insert	Standard									
PRGN ^{R/L} ...-12			090300	120400	Applications	Medium - Roughing						
												
			Size	09, 12								
			Page	B31								

Recommended Cutting Conditions ● D38~D39

External Turning Toolholders [WN□□ Insert]

DWLN (External / Facing)

					Side Rake Angle : -6° Angle of Inclination : -6°		● Applicable Inserts										
	● Right-hand shown		<table border="1"> <thead> <tr> <th>Toolholder Description</th> <th>Insert Description</th> </tr> </thead> <tbody> <tr> <td>DWLN^{R/L}...-08</td> <td>WN□A WN□G 0804... WN□M</td> </tr> </tbody> </table>		Toolholder Description	Insert Description	DWLN ^{R/L} ...-08	WN□A WN□G 0804... WN□M									
Toolholder Description	Insert Description																
DWLN ^{R/L} ...-08	WN□A WN□G 0804... WN□M																
Description	Stock		Dimension (mm)							Std. Corner-R(RE)	Spare Parts						
	R	L	H	HF	B	LF	LH	WF	Clamp		Screw	Spring	Shim	Shim Screw	Wrench	Wrench (sold separately)	
DWLN ^{R/L} 2020K -08	●	●	20	20	20	125	34	25	0.8								
2525M -08	●	●	25	25	25	150		32		CP-3D	CS-3D	SP-3D	DW-44	SB-4085TR	LW-3	FT-15	

Recommended tightening torque 3.9N·m

DWLN-JCT (External / Facing and Coolant-through Holders)

									Side Rake Angle : -6° Angle of Inclination : -6° Coolant supply : 3 directions		2020K-08JCT		● Applicable Inserts				
	● Right-hand shown		<table border="1"> <thead> <tr> <th>Toolholder Description</th> <th>Insert Description</th> </tr> </thead> <tbody> <tr> <td>DWLN^{R/L}...-08JCT</td> <td>WN□A WN□G 0804... WN□M</td> </tr> </tbody> </table>		Toolholder Description	Insert Description	DWLN ^{R/L} ...-08JCT	WN□A WN□G 0804... WN□M									
Toolholder Description	Insert Description																
DWLN ^{R/L} ...-08JCT	WN□A WN□G 0804... WN□M																
Description	Stock		Dimension (mm)							Std. Corner-R(RE)	Spare Parts						
	R	L	H	HF	B	LF	LH	WF	MHD		Clamp	Pipe Connection (* with O-ring)	Screw	Spring	Shim	Shim Screw	Wrench
DWLN ^{R/L} 2020K -08JCT	●	●	20	20	20	125	27	25	109	0.8							
2525M -08JCT	●	●	25	25	25	150		32	134		CP-3D- ^{R/L} -JCT	FP-12	CS-3D-TR	SP-3D	DW-44	SB-4085TR	FT-15

Please see page D10 and D11 for piping parts of coolant-through holders.

*1 It is possible to order just an O-ring (SS-035).

Recommended tightening torque 3.9N·m

● : Std. Item

PWLN (External / Facing)

Side Rake Angle : -6°
Angle of Inclination : -6°

● Applicable Inserts

Toolholder Description	Insert Description	
PWLN [®] /L...-06	WN□A WN□G	0604..
PWLN [®] /L...-08	WN□M	0804..

● Right-hand shown

Description	Stock		Dimension (mm)							Std. Corner-R(RE)	Spare Parts					
	R	L	H	HF	B	LF	LH	WF	Lever		Lock Screw	Shim	Shim Pin	Punch	Wrench	
PWLN [®] /L	●	●	16	16	16	100		20	0.8	LL-1N	LS-1N	LW-32N	LSP-1	PC-1	FH-2.5 LW	
1616H -06	●	●	20	20	20	125	22	25		0.8	LL-2N	LS-2N	LW-42N	LSP-2	PC-2	LW-3
2020K -06	●	●	25	25	25	150		32								
2525M -06	●	●	20	20	20	125	26	25								
2020K -08	●	●	25	25	25	150		32								
2525M -08	●	●														

When using inserts whose corner-R(RE) is greater than 1.6mm, additional modifications to the shim are necessary in order to prevent workpiece and shim from interfering each other.

WWLN (External / Facing)

Side Rake Angle : -6°
Angle of Inclination : -6°

WWLN[®]/2020K types,
Shim Nut sticks out as
shown below.

● Applicable Inserts

Toolholder Description	Insert Description	
WWLN [®] /L...-08	WN□A WN□G WN□M	0804..

● Right-hand shown

Description	Stock		Dimension (mm)							Std. Corner-R(RE)	Spare Parts				
	R	L	H	HF	B	LF	LH	WF	Clamp Set		Shim	Shim Pin	Shim Nut	Wrench	
WWLN [®] /L	●	●	20	20	20	125	30	25	1.2	WCS-8	WWN-42	WP5X15	WN-1	LW-3	
2020K -08	●	●	25	25	25	150		32							
2525M -08															

● Applicable Inserts

Applications	Finishing	Finishing - Medium	Finishing	Finishing - Medium	Finishing - Medium	Finishing - Medium	Medium - Roughing	Medium - Roughing	Medium - Roughing
Insert	WF(Wiper)	WE(Wiper)	PP	PQ	CQ	CJ	GS	PG	PS
Size	08	08	08	08	08	08	06,08	08	08
Page	B46	B46	B46	B46	B47	B47	B47	B47	B47
Applications	Medium - Roughing / High Feed Rate	Roughing	Finishing	Medium	Soft Steel / Finishing	Soft Steel / Medium	Soft Steel / Roughing	Stainless Steel / Finishing	Stainless Steel / Medium-Roughing
Insert	PT	Standard	¾-S	¾	XP	XQ	XS	MQ	MS
Size	08	08	06	06	08	08	08	08	08
Page	B47	B47	B49	B49	B48	B48	B48	B48	B48
Applications	Stainless Steel / Medium-Roughing	Cast Iron	Cast Iron	Cast Iron	Cast Iron	Cast Iron	Non-ferrous Metals	Non-ferrous Metals	Hard Materials
Insert	MU	KQ	KG	KH	ZS	GC	AH	PCD	CBN
Size	08	08	08	08	08	08	08	08	08
Page	B48	B49	B49	B49	B49	B49	B49	C23	C13

In wedge lock, use of ceramic insert other than silicon nitride insert is not recommended due to strong restrain force.

Recommended Cutting Conditions ● D38~D39

● : Std. Item

CCLN (External / Facing)

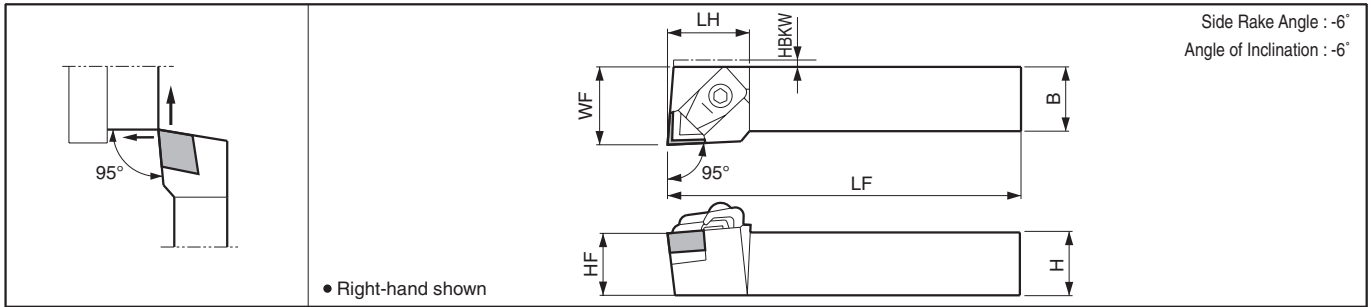

Toolholder Dimensions

Description	Stock		Dimension (mm)								Std. Corner-R(RE)	Spare Parts				
	R	L	H	HF	B	LF	LH	WF	HBKW	Chipbreaker		Clamp Set	Wrench	Shim	Shim Screw	
CCLN ^{R/L}	2020K -12	●	●	20	20	20	125	32	27	5	0.8	CB-16	CE-010	LW-4	SP-441 (SP-443)	M3X8 (M3X12)
	2525M -12	●	●	25	25	25	150	32	32	-		CB-17	CE-220	LW-4	SP-454	M4X10
	3225P -16	●	●	32	32	25	170	35	32	-		0.8	CB-17	CE-220	LW-4	SP-454

Shim & Shim Screw : When using CN□□1204 Insert, please purchase spare parts in () separately.

Applicable Inserts

Applications See Page	Cast Iron / Hard Materials	Hard Materials / Cast Iron
Toolholder Description	B106 Ceramic 	C19 CBN (KBN900)
	CCLN ^{R/L} ...-12	CNGN1207..(CNGN1204..) CNMN1207
CCLN ^{R/L} ...-16	CNGN1607..	-

Recommended Cutting Conditions **D38~D39**

Selection of Ceramic Insert

Select the suitable Ceramic Insert and Specifications (Corner-R(RE), Feed Rate, Chamfer, etc.) from the table below.

(FC250, Cutting Edge Angle: 0°~15°)

Insert Shape	Corner-R (RE)	f (mm/rev)										ap (mm)
		0.10	0.15	0.20	0.25	0.30	0.35	0.40	0.45	0.50	0.60	
RN	-	→										0.3~4
SN	2.0	→										0.3~4
	1.6	→										
	1.2	→										
EN	1.2	→										0.3~4
	0.8	→										
	0.4	→										
TN	1.6	→										0.3~2
	1.2	→										
	0.8	→										
Chamfer		0.05mm x 20°		(0.1~0.2)mm x (20°~25°)				0.3mm x 30°				-
Insert Thickness		7.94mm										-

● : Std. Item

CDJN (External / Copying / Back Turning)

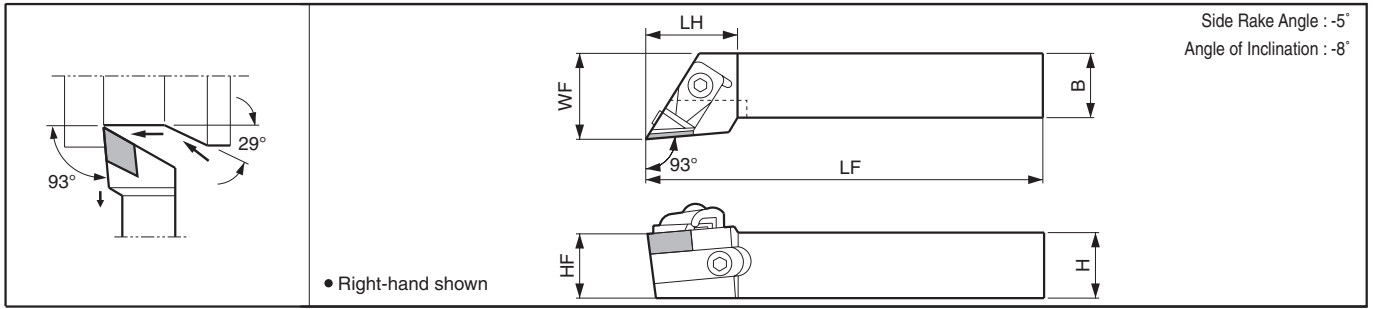

Toolholder Dimensions

Description	Stock		Dimension (mm)						Std. Corner-R(RE)	Spare Parts				
	R	L	H	HF	B	LF	LH	WF		Chipbreaker	Clamp Set	Wrench	Shim	Shim Screw
	CDJN^{R/L}	●	●	25	25	25	150	32		32	0.8			
3225P -15	●	●	32	32	25	170								

• Chipbreaker : CB-14 for Right-hand Toolholder, CB-15 for Left-hand Toolholder.
• Shim : 556CR for Right-hand Toolholder, 556CL for Left-hand Toolholder.

Applicable Inserts

Applications	Cast Iron / Hard Materials
See Page	B107
Insert	Ceramic
Toolholder Description	DNGN1507..
CDJN^{R/L}...-15	DNGN1507..

Recommended Cutting Conditions **D38~D39**

CELN (External / Facing)

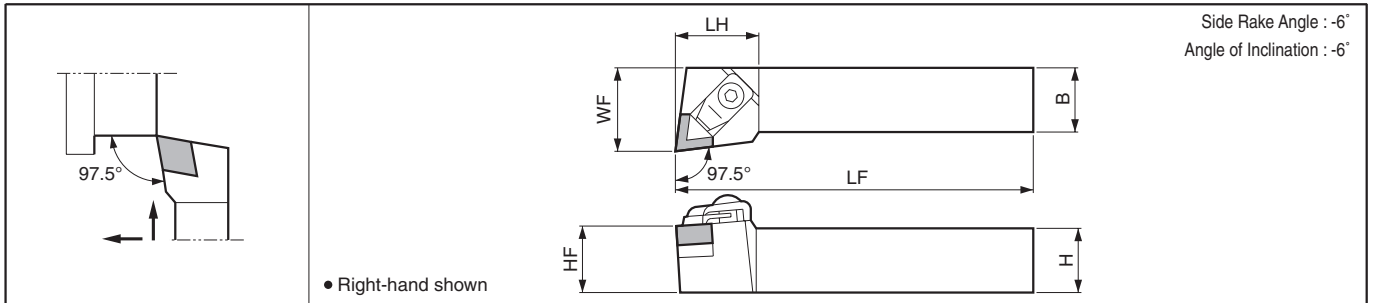

Toolholder Dimensions

Description	Stock		Dimension (mm)						Std. Corner-F(RE)	Spare Parts				
	R	L	H	HF	B	LF	LH	WF		Chipbreaker	Clamp Set	Wrench	Shim	Shim Screw
	CELN^{R/L}	●	●	25	25	25	150	32		32	0.8			

Applicable Inserts

Applications	Cast Iron / Hard Materials
See Page	B107
Insert	Ceramic
Toolholder Description	ENGN1307..
CELN^{R/L}...-13	ENGN1307..

Recommended Cutting Conditions **D38~D39**

CSRN (External)

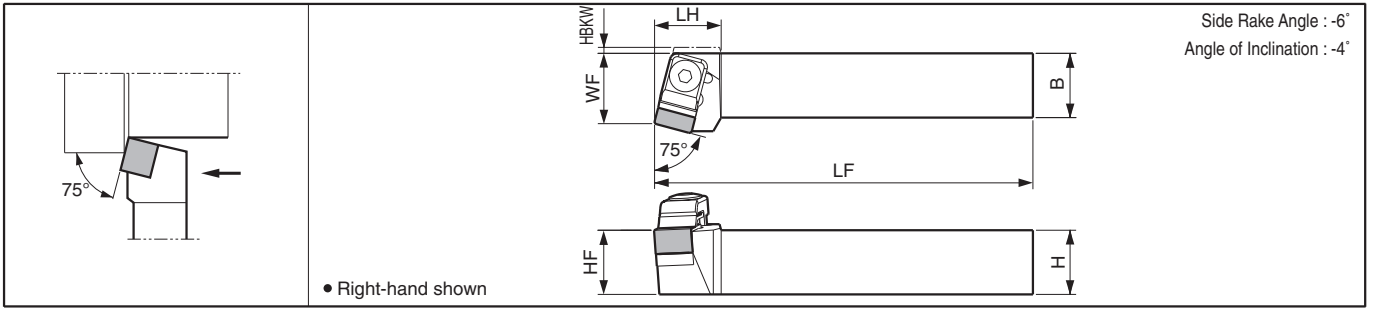

CS-N (External)

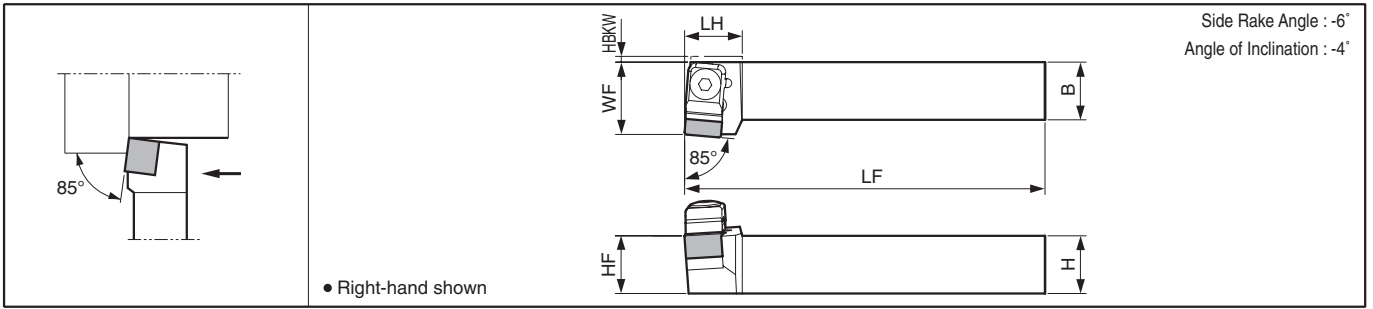

CSKN (Facing)

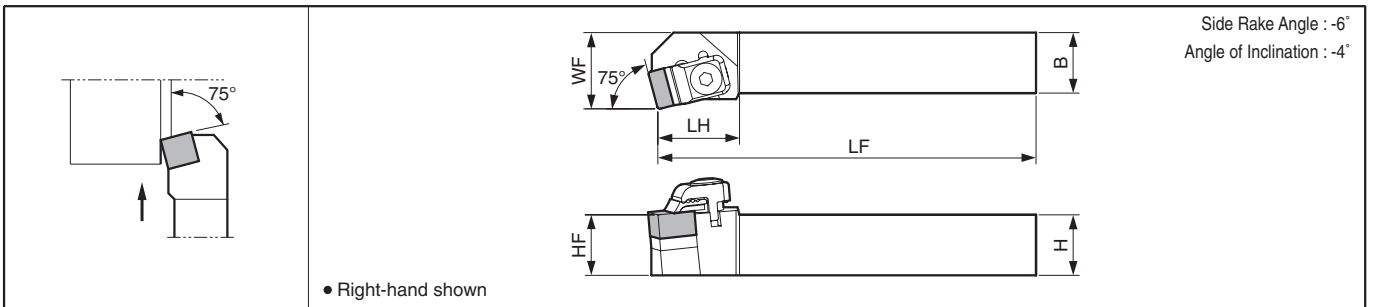

CSYN (Facing)

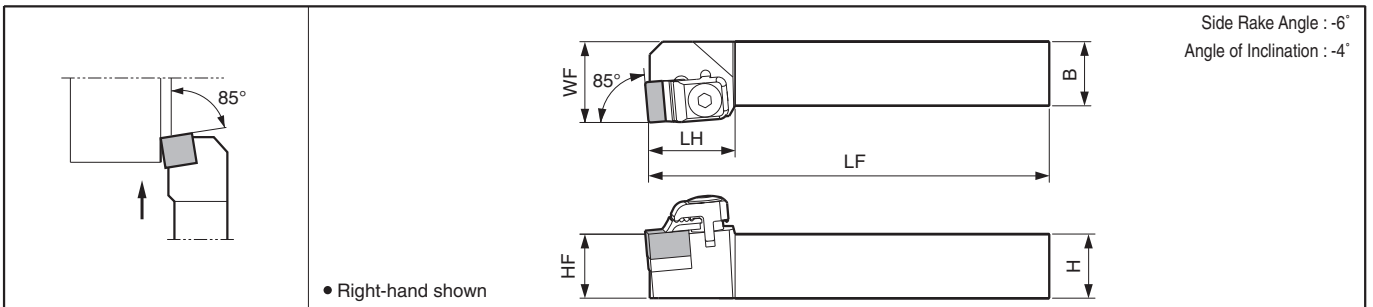

CSSN (External / Facing / Chamfering)

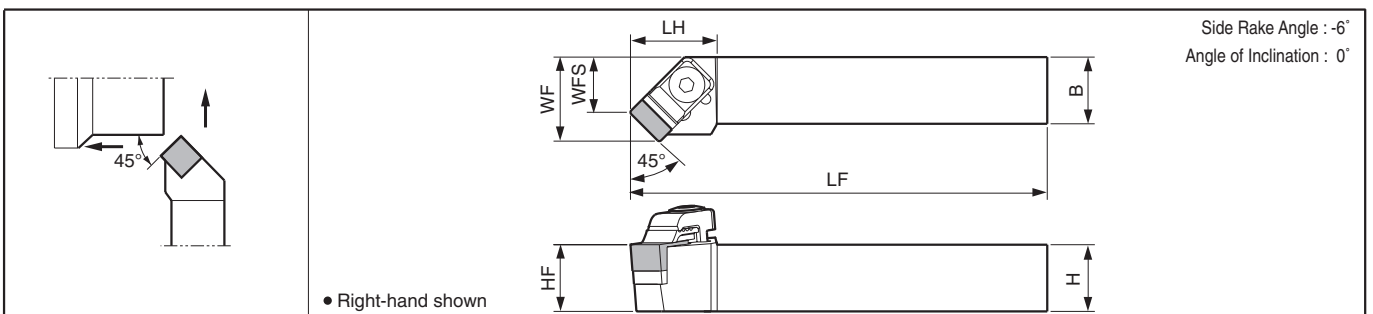

D
External

CSDN (External / Chamfering)

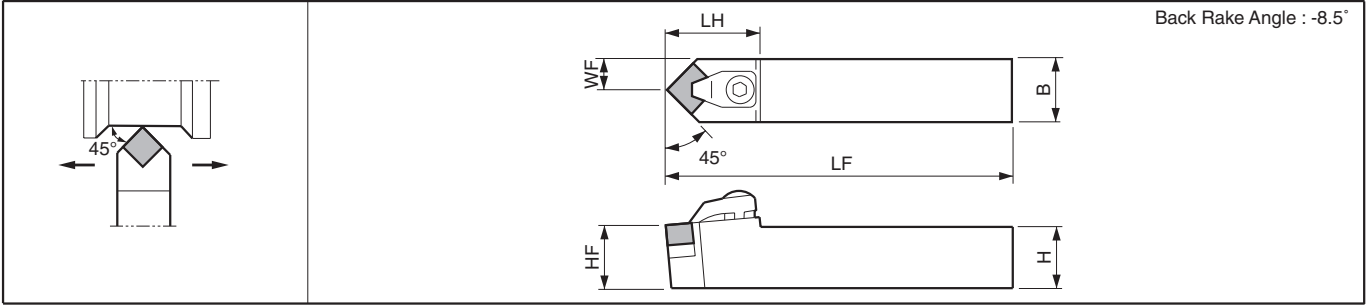

● Toolholder Dimensions

Description	Stock		Dimension (mm)										Std. Corner-R(RE)	Spare Parts				
	R	N	L	H	HF	B	LF	LH	WF	HBKW	WFS	Chipbreaker		Clamp Set	Wrench	Shim	Shim Screw	
CSRN ^{P/L}	2020K -12	●	●	20	20	20	125		22	2	-	0.8		CE-020	LW-4	SP-141 (SP-143)	M3X8 (M3X12)	
	2525M -12	●	●	25	25	25	150	22	27	-	-							
	3225P -12	●	●	32	32	25	170											
	3225P -15	●		32	32	25	170	30	32.4	-	-							
	4040R -15	●	●	40	40	40	200		43	-	-							
CS-N ^{P/L}	2525M -12	●	●	25	25	25	150	20	32	-	-	0.8	CB-11	CE-020	LW-4	SP-141 (SP-143)	M3X8 (M3X12)	
CSKN ^{P/L}	2020K -12	●		20	20	20	125	27	25	-	-	0.8	CB-11	CE-020	LW-4	SP-141 (SP-143)	M3X8 (M3X12)	
	2525M -12	●	●	25	25	25	150		32	-	-							
	3225P -15	●		32	32	25	170	37	32	-	-							
CSYN ^{P/L}	2525M -12	●	●	25	25	25	150	27	32	-	-	0.8	CB-11	CE-020	LW-4	SP-141 (SP-143)	M3X8 (M3X12)	
CSSN ^{P/L}	2020K -12	●		20	20	20	125	26	25	-	16	0.8	CB-11	CE-020	LW-4	SP-141 (SP-143)	M3X8 (M3X12)	
	2525M -12	●	●	25	25	25	150		32	-	23							
CSDNN	2020K -12		●	20	20	20	125		10	-	-	0.8	-	CE-040	LW-4	SP-141 (SP-143)	M3X8 (M3X12)	
	2525M -12		●	25	25	25	150	32	12.5	-	-							
	3225P -12		●	32	32	25	170			-	-							

Shim & Shim Screw : When using SN□□1204 Insert, please purchase spare parts in () separately.

● Applicable Inserts

Applications See Page	Cast Iron / Hard Materials		Cast Iron		Hard Materials / Cast Iron		When using as toolholder for CBN tools (KBN900), please purchase spare parts below separately.		
	B109,B110		B35		C19		Clamp Set	Shim	Shim Screw
Toolholder Description	Ceramic		Coated Carbide		CBN (KBN900)				
CSRN ^{P/L} ...-12	SNGN1207..(SNGN1204..) SNMN1207..		(SNMN1204..)		(SNMN1204..)		CE-030A	SP-143	M3X12
CSRN ^{P/L} ...-15	SNGN1507..		-		-				
CS-N ^{P/L} ...-12	SNGN1207..(SNGN1204..) SNMN1207..		(SNMN1204..)		(SNMN1204..)		CE-030A	SP-143	M3X12
CSKN ^{P/L} ...-12	SNGN1207..(SNGN1204..) SNMN1207..		(SNMN1204..)		(SNMN1204..)		CE-030A	SP-143	M3X12
CSKN ^{P/L} ...-15	SNGN1507..		-		-				
CSYN ^{P/L} ...-12	SNGN1207..(SNGN1204..) SNMN1207..		(SNMN1204..)		(SNMN1204..)		CE-030A	SP-143	M3X12
CSSN ^{P/L} ...-12	SNGN1207..(SNGN1204..) SNMN1207..		(SNMN1204..)		(SNMN1204..)		CE-030A	SP-143	M3X12
CSDNN ...-12	SNGN1207..(SNGN1204..) SNMN1207..		(SNMN1204..)		(SNMN1204..)		* -	SP-143	M3X12

* CSDNN...-12 : Clamp Set CE-040 is used continuously.
Recommended Cutting Conditions ● D38~D39

CTJN (External)

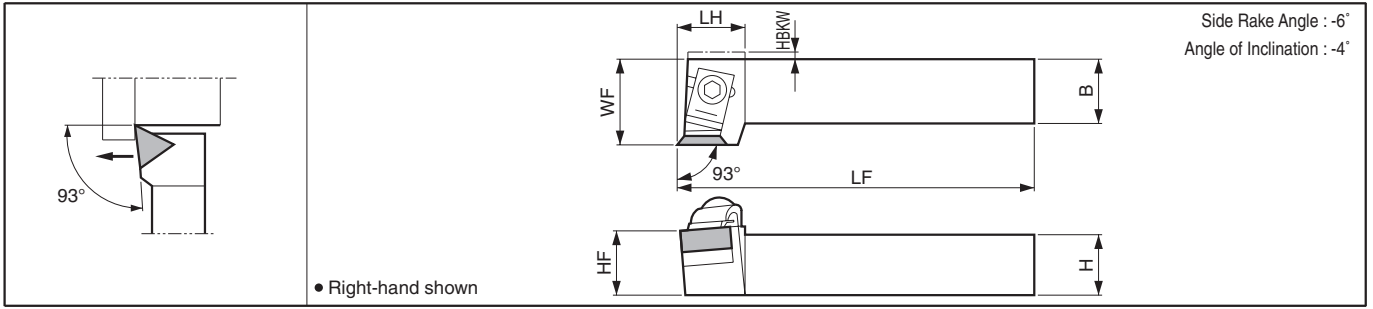

CTUN (Facing)

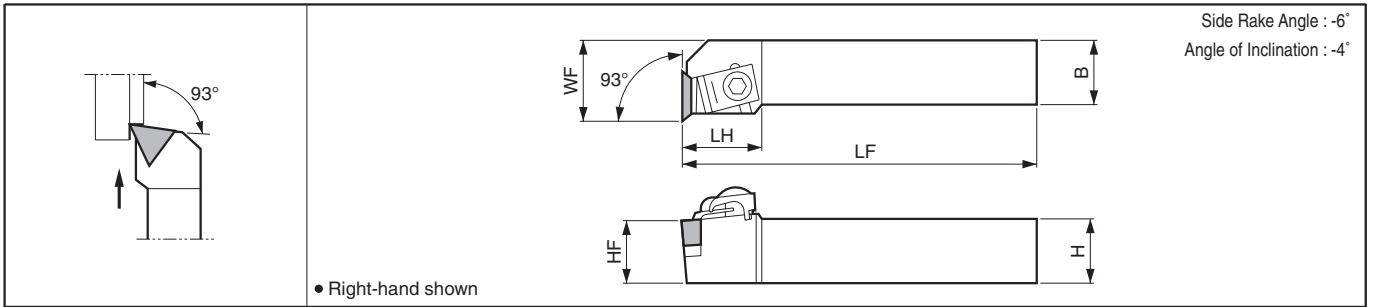

Toolholder Dimensions

Description	Stock		Dimension (mm)							Std. Corner-R/(RE)	Spare Parts					
	R	L	H	HF	B	LF	LH	WF	HBKW		Chipbreaker	Clamp Set	Wrench	Shim	Shim Screw	
CTJN ^{R/L}	2020K -16	●	●	20	20	20	125	21	25	2	0.8	CB-12/13	CE-020	LW-4	SP-221 (SP-223)	M3X8 (M3X12)
	2525M -16	●	●	25	25	25	150		32	-						
CTUN ^{R/L}	2020K -16	●	●	20	20	20	125	27	25	-	0.8	CB-13/12	CE-020	LW-4	SP-221 (SP-223)	M3X8 (M3X12)
	2525M -16	●	●	25	25	25	150		32	-						

- CTJN (Chipbreaker) : CB-12 for Right-hand Toolholder, CB-13 for Left-hand Toolholder.
- CTUN (Chipbreaker) : CB-13 for Right-hand Toolholder, CB-12 for Left-hand Toolholder.
- Shim & Shim Screw : When using TN□□1604 Insert, please purchase spare parts in () separately.

Applicable Inserts

Applications	Cast Iron / Hard Materials	Hard Materials / Cast Iron
See Page	B111	C19
Toolholder Description	Ceramic 	CBN (KBN900)
	CTJN ^{R/L} ...-16	(TNMN1604..)
CTUN ^{R/L} ...-16	TNGN1607.. (TNGN1604..) (TNMN1604..)	

Recommended Cutting Conditions D38~D39

CRSN (External / Facing)

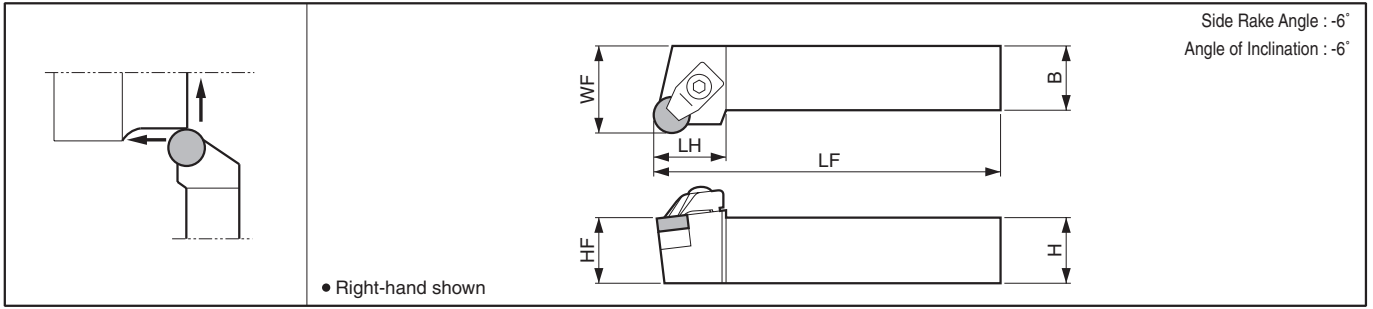

CRDN (External / Copying)

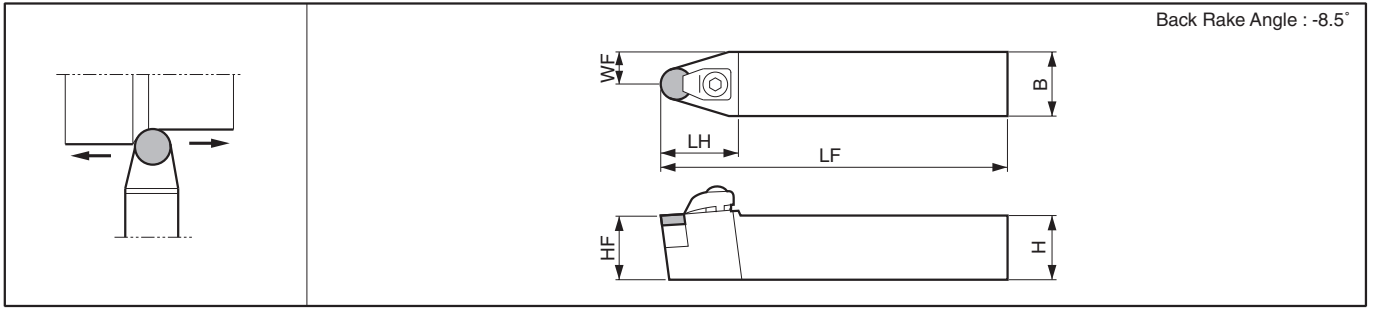

Toolholder Dimensions

Description	Stock		Dimension (mm)							Std. Corner-R(RE)	Spare Parts			
	R	N	L	H	HF	B	LF	LH	WF		Clamp Set	Wrench	Shim	Shim Screw
CRSN ^{R/L}	2020K -12	●	●	20	20	20	125		25	-	CE-030	LW-4	SP-841 (SP-843)	M3X8 (M3X12)
	2525M -12	●	●	25	25	25	150	26	32					
	3225P -12	●	●	32	32	25	170							
CRDNN	2020K -12		●	20	20	20	125		10	-	CE-030	LW-4	SP-841 (SP-843)	M3X8 (M3X12)
	2525M -12		●	25	25	25	150	28	12.5					
	3225P -12		●	32	32	25	170							
	3232P -15		●	32	32	32	170							
4040R -15		●	40	40	40	200	35	16 20		CE-040	LW-4	SP-861	M4X10	

• Shim & Shim Screw : When using RN□□1204 Insert, please purchase spare parts in () separately.

Applicable Inserts

Applications See Page	Cast Iron / Hard Materials	Hard Materials / Cast Iron	When using as toolholder for CBN tools (KBN900), please purchase spare parts below separately.		
Toolholder Description	Insert	C19 CBN (KBN900)	Clamp Set	Shim	Shim Screw
			CRSN ^{R/L} ...-12	RNGN120700(RNGN120400)	(RNMN120400)
CRDNN ...-12	RNGN120700(RNGN120400)	(RNMN120400)	CE-030A	SP-843	M3X12
CRDNN ...-15	RNGN150700	-			

Recommended Cutting Conditions ● D38~D39

CCRN-A (External)

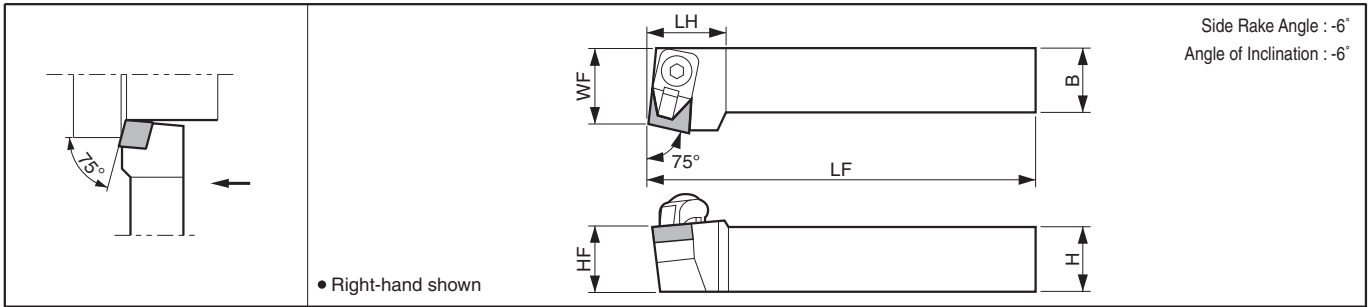

CCLN-A (External / Facing)

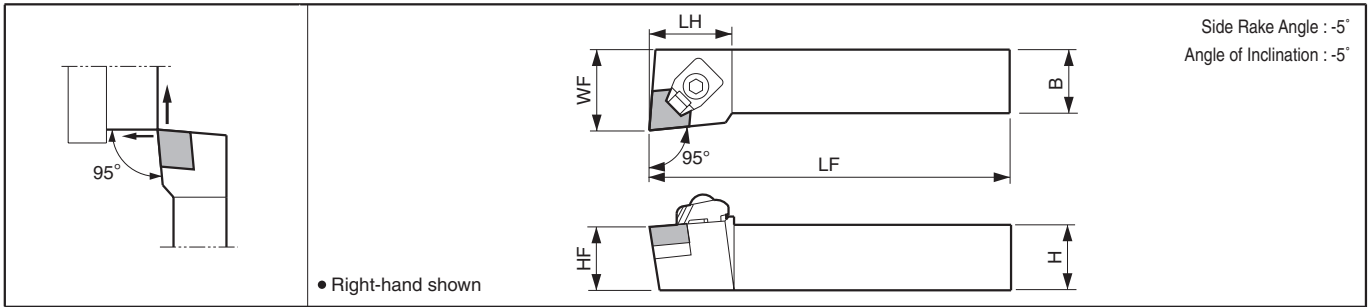

Toolholder Dimensions

Description	Stock		Dimension (mm)							Std. Corner-R(RE)	Spare Parts			
	R	L	H	HF	B	LF	LH	WF	Clamp Set		Wrench	Shim	Shim Screw	
	CCRN ^{R/L} 2525M-09A	●	●	25	25	25	150	27	27		0.8			
CCLN ^{R/L} 2525M-09A	●	●	25	25	25	150	28	32	0.8					

Applicable Inserts

Applications	Hard Materials / Cast Iron
See Page	C19
Insert	CBN (KBN900)
Toolholder Description	
CCRN ^{R/L} ...-09A	CNMN0903..
CCLN ^{R/L} ...-09A	

* For CNMN1204 Insert toolholder, see page D26

Recommended Cutting Conditions D38~D39

CRSN-A (External / Facing)

Side Rake Angle : -6°
Angle of Inclination : -6°

● Right-hand shown

CRDN-A (External / Copying)

Back Rake Angle : -8.5°

Toolholder Dimensions

Description	Stock		Dimension (mm)								Std. Corner-R(RE)	Spare Parts				
	R	N	L	H	HF	B	LF	LH	WF	Clamp Set		Wrench	Shim		Shim Screw	
CRSN ^{R/L}	2525M-09A	●	●	25	25	25	150	26	32	-	CE-030A	LW-4	SP-829	-	HH3X12	
	3225P-09A	●	●	32	32		170							SP-849 (SP-843)	BH3X12	
	2525M-12A	●	●	25	25	150	-	BH3X12								
	3225P-12A	●	●	32	32	170		BH3X12								
CRDNN	2525M-09A		●	25	25	25	150	29	12.5	-	CE-030A	LW-4	SP-829	-	HH3X12	
	3225P-09A		●	32	32		170							-	BH3X12	
	2525M-12A		●	25	25	150	-	BH3X12								
	3225P-12A		●	32	32	170		BH3X12								

-12A toolholder Shim : When using RN□□1204 Insert, please purchase spare parts : SP-843 in () separately.

Applicable Inserts

Applications See Page	Hard Materials / Cast Iron	Cast Iron / Hard Materials	When using as toolholder for ceramic tools, please purchase spare parts below separately.	
Toolholder Description	C19 CBN (KBN900)	Ceramic	Shim	Shim Screw
CRSN ^{R/L} ...-09A	RNMN090300	(RNGN090400)	SP-826	-
CRSN ^{R/L} ...-12A	RNMN120300 (RNMN120400)	(RNGN120400)	SP-843	M3X12
		(RNGN120700)	SP-841	M3X8
CRDNN...-09A	RNMN090300	(RNGN090400)	SP-826	-
CRDNN...-12A	RNMN120300 (RNMN120400)	(RNGN120400)	SP-843	M3X12
		(RNGN120700)	SP-841	M3X8

Recommended Cutting Conditions ● D38~D39

CSRN-A (External)

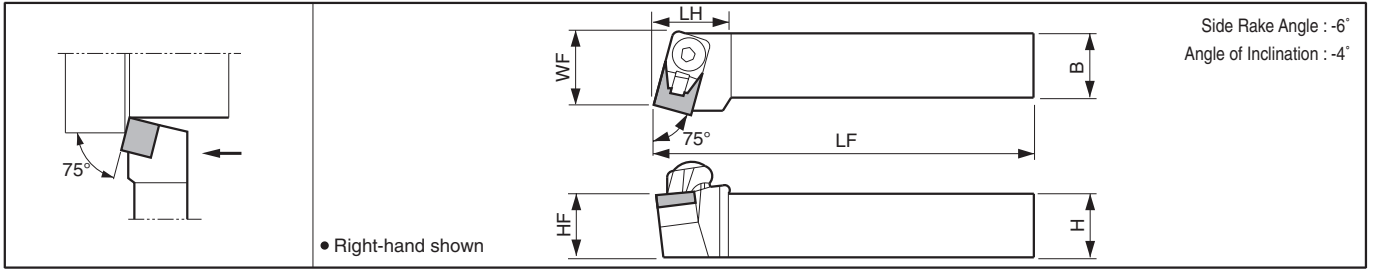

CSKN-A (Facing)

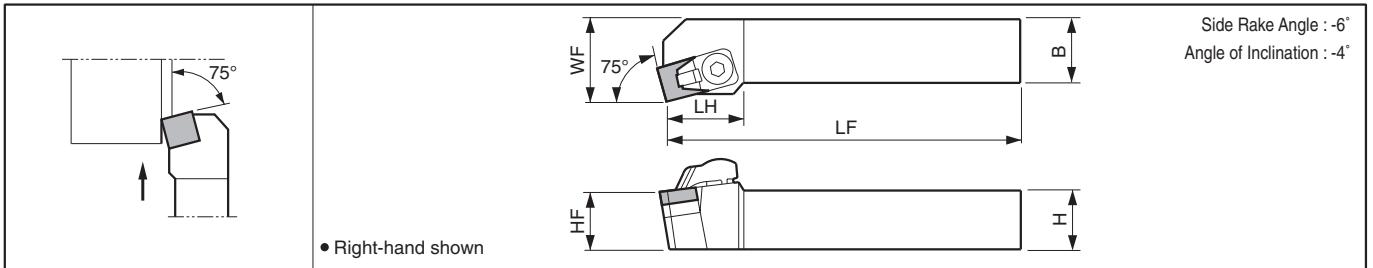

Toolholder Dimensions

Description	Stock		Dimension (mm)							Std. Corner:R(RE)	Spare Parts				
	R	L	H	HF	B	LF	LH	WF	Clamp Set		Wrench	Shim	Shim Screw		
CSRN^{R/L} 2525M-12A	●	●	25	25	25	150	22	27	0.8			-			
CSKNR 2525M-09A	●		25	25	25	150	27	32	0.8						

-12A toolholder Shim : When using SN□□1204 Insert, please purchase spare parts : SP-143 in () separately.

Applicable Inserts

Applications	Hard Materials / Cast Iron	Cast Iron	Cast Iron / Hard Materials	When using as toolholder for ceramic tools, please purchase spare parts below separately.			
See Page	C19	B35	B109,B110	Chipbreaker	Clamp Set	Shim	Shim Screw
Insert							
Toolholder Description							
CSRN^{R/L}...-12A	SNMN1203.. (SNMN1204..)	(SNMN1204..)	(SNGN1204..) (SNMN1204..) (SNGN1207..) (SNMN1207..)	CB-11	CE-020	SP-143 SP-141	M3X12 M3X8
CSKN^{R/L}...-09A	SNMN0903..	-	-	-	-	-	-

Recommended Cutting Conditions **D38~D39**

CSSN-A (External / Facing / Chamfering)

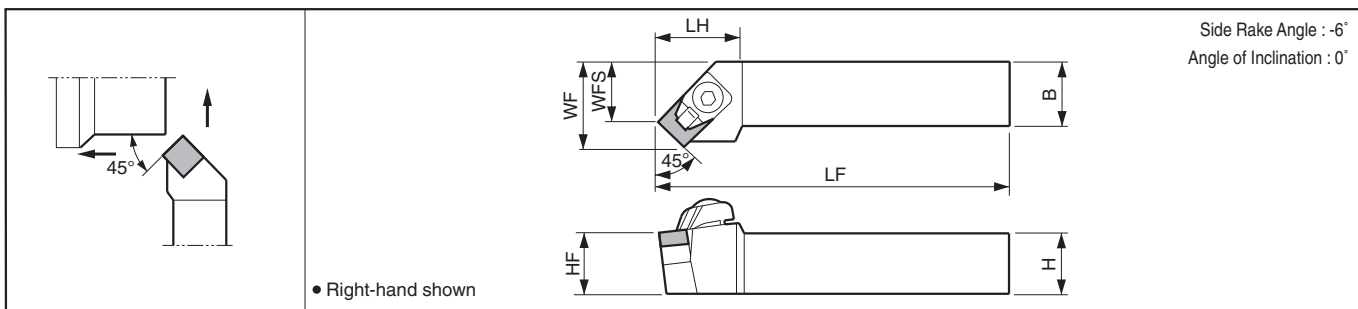

CSDN-A (External / Chamfering)

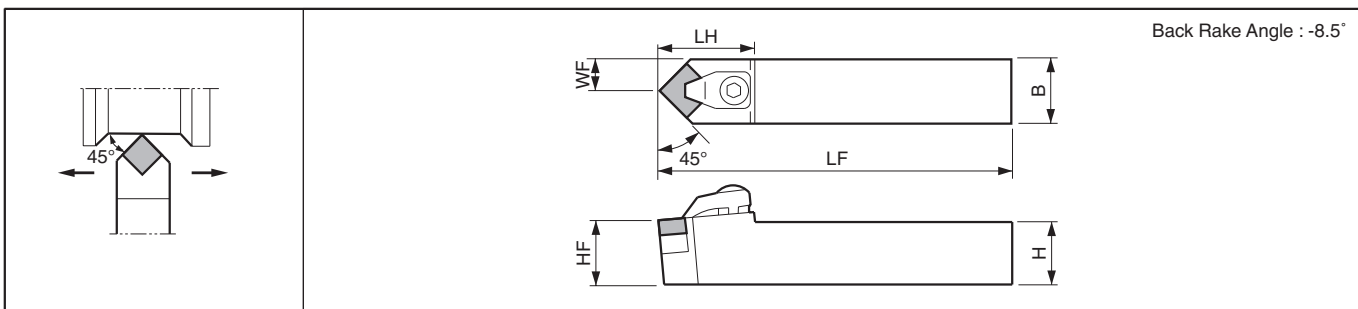

● Toolholder Dimensions

Description	Stock		Dimension (mm)								Std. Corner R(RE)	Spare Parts					
	R	N	L	H	HF	B	LF	LH	WF	WFS		Clamp Set	Wrench	Shim		Shim Screw	
CSSN ^{F/L}	●	●		25	25	25	150	26	32	25	0.8	CE-030A	LW-4	SP-129	-	HH3X12	
														-	SP-148 (SP-143)	BH3X12	
CSDNN	●	●		25	25	25	150	32	12.5	-	0.8	CE-040	LW-4	SP-129	-	HH3X12	
														-	SP-148 (SP-143)	BH3X12	

-12A toolholder Shim: When using SN□□1204 Insert, please purchase spare parts : SP-143 in () separately.

● Applicable Inserts

Applications See Page	Hard Materials / Cast Iron	Cast Iron	Cast Iron / Hard Materials		When using as toolholder for ceramic tools, please purchase spare parts below separately.			
	C19	B35	B109,B110	Ceramic	Chipbreaker	Clamp Set	Shim	Shim Screw
Insert	CBN (KBN900)	Coated Carbide						
Toolholder Description								
CSSN ^{F/L} ...-09A	SNMN0903..	-	-	-	-	-	-	-
CSSN ^{F/L} ...-12A	SNMN1203.. (SNMN1204..)	(SNMN1204..)	(SNGN1204..) (SNMN1204..) (SNGN1207..) (SNMN1207..)	CB-11	CE-020	SP-143 SP-141	M3X12 M3X8	
CSDNN...-09A	SNMN0903..	-	-	-	-	-	-	
CSDNN...-12A	SNMN1203.. (SNMN1204..)	(SNMN1204..)	(SNGN1204..) (SNMN1204..) (SNGN1207..) (SNMN1207..)	-	-	SP-143 SP-141	M3X12 M3X8	

Recommended Cutting Conditions ➔ D38~D39

CTJN-A (External)

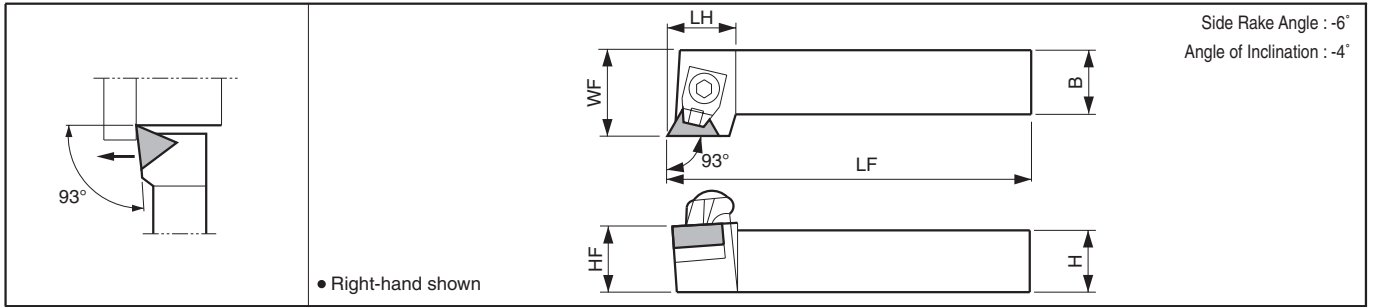

Toolholder Dimensions

Description	Stock		Dimension (mm)							Std. Corner-R(RE)	Spare Parts			
	R	L	H	HF	B	LF	LH	WF	Clamp Set		Wrench	Shim	Shim Screw	
CTJN^{R/L} 2525M-11A	●	●	25	25	25	150	22	32	0.8					

Applicable Inserts

Applications See Page	Hard Materials / Cast Iron	Cast Iron / Hard Materials
Insert Toolholder Description	C19 CBN (KBN900) 	B111 Ceramic
	CTJN^{R/L}...-11A	TNMG1103.. / TNGN1103..

* TNMN1604 Insert toolholder is described in **D30**.

Recommended Cutting Conditions **D38~D39**

Toolholders for Bearing Machining

PRGC-BE (External)

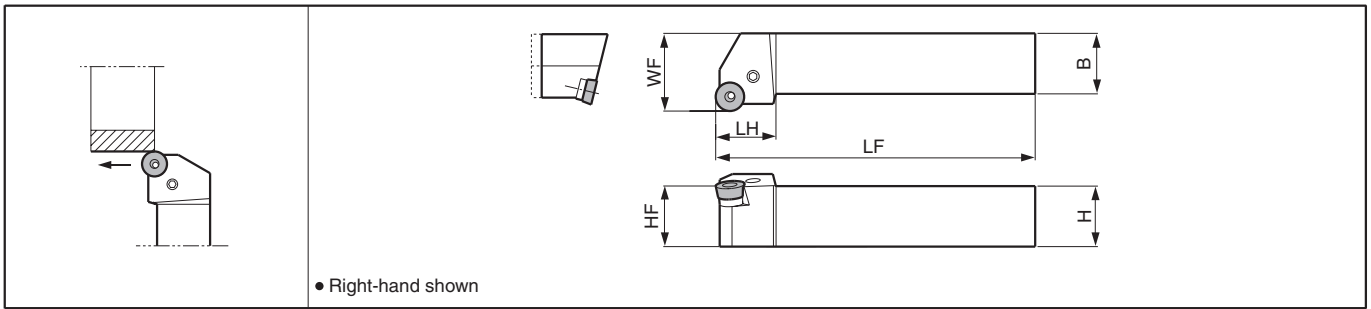

Toolholder Dimensions

Description	Stock	Dimension (mm)						Spare Parts						Applicable Inserts ➔ B103
		H	HF	B	LF	LH	WF	Lever	Lock Screw	Shim	Shim Pin	Punch	Wrench	
PRGCR 2525M-12BE	●	25	25	25	150	25	32	LL-1CN	LS-1N	LR-12C	LSP-1	PC-1	FH-2.5	RCMT 1204M0-BB

Recommended Cutting Conditions ➔ D38~D39

CBSN (External Round-Chamfering)

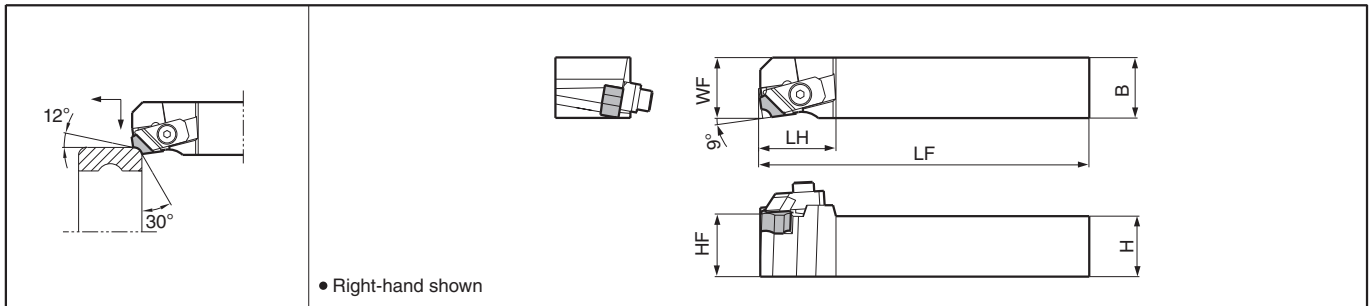

Toolholder Dimensions

Description	Stock		Dimension (mm)						Spare Parts				Applicable Inserts ➔ B103
	R	L	H	HF	B	LF	LH	WF	Clamp Set	Wrench	Shim	Shim Screw	
CBSN ^{R/L} 2020K-12	●	●	20	20	20	125	32	20	CP-RC ^{R/L}	LW-5	SP-RC	SP3X8	SNMF1204○○-21
2525M-12	●	●	25	25	25	150	25						

- Clamp Set : CP-RCR for Right-hand Toolholder, CP-RCL for Left-hand Toolholder.

Recommended Cutting Conditions ➔ D38~D39

Tooling for Bearing Machining

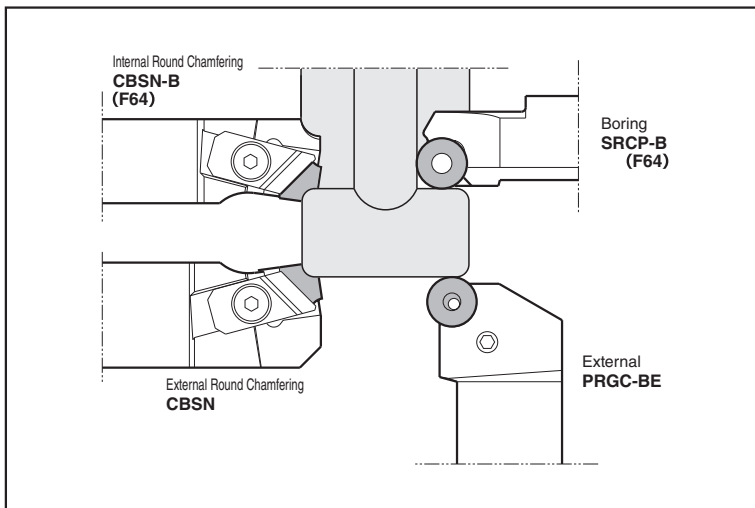

● : Std. Item

Insert Grades
Turning
Indexable Inserts
CNC & PC Tools
External
Small Parts
Boring
Grooving
Cut-off
Threading
Drilling
Milling
Tools for
Spindle Parts
Technical
Index

A
B
C
D
E
F
G
H
J
K
M
N
P
R
T

Recommended Cutting Conditions

Recommended Cutting Conditions - External Turning (Negative Insert) [ap indicates radius]

ISO Classification	Workpiece Material	Hardness	Cutting Range	Applications	Recommended Chipbreaker	Recommended Insert Grade	Corner-R (RE)	Lower Limit - Recommendation - Upper Limit		
								Vc (m/min)	ap (mm)	f (mm/rev)
P	Low Carbon Steel Low Carbon Alloy	HB ≤ 300	Finishing (High Speed Machining)	Continuous	XP	CCX	0.8	300 - 600 - 800	0.2 - 0.5 - 0.7	0.07 - 0.12 - 0.2
			Finishing (Small ap)	Continuous Interruption	XF	PV710 PV720	0.4 0.8	250 - 350 - 520 240 - 320 - 480	0.05 - 0.12 - 0.6 0.05 - 0.15 - 0.6	0.03 - 0.1 - 0.22 0.04 - 0.12 - 0.25
			Finishing (Gloss Oriented)	Continuous Interruption	XP	TN610 TN620	0.4 0.8	250 - 320 - 400 240 - 310 - 370	0.2 - 0.5 - 0.7 0.2 - 0.5 - 0.7	0.07 - 0.12 - 0.2 0.07 - 0.12 - 0.2
			Finishing (Tool Life Oriented)	Continuous Interruption	XP	PV710 PV720	0.4 0.8	250 - 300 - 370 240 - 290 - 340	0.2 - 0.5 - 0.7 0.2 - 0.5 - 0.7	0.07 - 0.12 - 0.2 0.07 - 0.12 - 0.2
			Finishing - Medium (Gloss Oriented)	Continuous Interruption	XQ	TN610 TN620	0.4 0.8	250 - 320 - 400 240 - 280 - 340	0.5 - 1.0 - 1.5 0.5 - 1.0 - 1.5	0.17 - 0.25 - 0.3 0.17 - 0.25 - 0.3
			Finishing - Medium (Tool Life Oriented)	Continuous Interruption	XQ	PV710 PV720	0.8 0.8	250 - 300 - 370 240 - 280 - 340	0.5 - 1.0 - 1.5 0.5 - 1.0 - 1.5	0.17 - 0.25 - 0.3 0.17 - 0.25 - 0.3
			Medium - Roughing	Continuous Interruption	XS	PV720 CA515	0.8 0.8	220 - 260 - 320 160 - 210 - 260	0.8 - 1.5 - 2.0 0.8 - 1.5 - 2.0	0.25 - 0.3 - 0.4 0.25 - 0.3 - 0.4
			Roughing	Continuous Interruption	PG	CA515 CA025P	0.8 1.2	180 - 220 - 260 150 - 200 - 240	1.0 - 2.5 - 3.5 1.0 - 2.5 - 3.5	0.2 - 0.3 - 0.4 0.2 - 0.3 - 0.4
			Medium - Roughing High Feed Rate	Continuous Interruption	PT	CA515 CA025P	0.8 1.2	150 - 200 - 240 120 - 180 - 220	1.5 - 3.0 - 4.5 1.5 - 3.0 - 4.5	0.25 - 0.35 - 0.45 0.25 - 0.35 - 0.45
			Roughing High Feed Rate	Continuous Interruption	PH	CA515 CA025P	1.2 1.6	150 - 200 - 240 120 - 180 - 220	2.0 - 5.0 - 8.0 2.0 - 5.0 - 8.0	0.4 - 0.6 - 0.8 0.3 - 0.5 - 0.7
			Roughing (Low Cutting Force)	Continuous Interruption	PX (Single-sided)	CA515 CA025P	1.2 1.6	150 - 200 - 240 120 - 180 - 220	2.0 - 5.0 - 8.0 2.0 - 5.0 - 8.0	0.4 - 0.6 - 0.8 0.3 - 0.5 - 0.7
			Finishing (Time Oriented)	Continuous Interruption	WF (Wiper)	PV710 CA515	0.8 0.8	200 - 250 - 320 160 - 220 - 280	0.3 - 0.5 - 1.0 0.3 - 0.5 - 1.0	0.2 - 0.3 - 0.4 0.2 - 0.3 - 0.4
	Finishing - Medium (Time Oriented)	Continuous Interruption	WE (Wiper)	PV710 CA025P	0.8 0.8	180 - 220 - 280 130 - 180 - 240	1.0 - 2.0 - 3.0 1.0 - 2.0 - 3.0	0.2 - 0.3 - 0.4 0.2 - 0.3 - 0.4		
	Finishing (High Speed Machining)	Continuous	PP	CCX	0.8	200 - 300 - 450	0.2 - 0.5 - 1.5	0.04 - 0.16 - 0.28		
	Finishing (Gloss Oriented)	Continuous Interruption	PP	TN610	0.4 0.8	200 - 250 - 320 180 - 230 - 300	0.2 - 0.5 - 1.5 0.2 - 0.5 - 1.5	0.04 - 0.16 - 0.28 0.05 - 0.2 - 0.35		
	Finishing (Tool Life Oriented)	Continuous Interruption	PP	PV710 PV720	0.4 0.8	200 - 250 - 320 200 - 240 - 290	0.2 - 0.5 - 1.5 0.2 - 0.5 - 1.5	0.04 - 0.16 - 0.28 0.05 - 0.2 - 0.35		
	Finishing - Medium (Gloss Oriented)	Continuous Interruption	PQ	TN610 TN620	0.8 1.2	180 - 230 - 300 160 - 220 - 260	0.5 - 1.5 - 2.5 0.5 - 1.5 - 2.5	0.1 - 0.2 - 0.3 0.1 - 0.17 - 0.25		
	Finishing - Medium (Tool Life Oriented)	Continuous Interruption	PQ	PV710 CA025P	0.8 0.8	160 - 210 - 280 140 - 200 - 240	0.5 - 1.5 - 2.5 0.5 - 1.5 - 2.5	0.1 - 0.2 - 0.3 0.1 - 0.17 - 0.25		
	Medium - Roughing	Continuous Interruption	PG	CA515 CA025P	0.8 1.2	150 - 200 - 240 120 - 160 - 200	1.0 - 2.5 - 3.5 1.0 - 2.5 - 3.5	0.2 - 0.3 - 0.4 0.2 - 0.3 - 0.4		
	Medium - Roughing High Feed Rate	Continuous Interruption	PT	CA515 CA025P	0.8 1.2	120 - 180 - 230 100 - 150 - 200	1.5 - 3.0 - 4.5 1.5 - 3.0 - 4.5	0.25 - 0.35 - 0.45 0.25 - 0.35 - 0.45		
	Roughing High Feed Rate	Continuous Interruption	PH	CA515 CA025P	1.2 1.6	120 - 180 - 230 100 - 150 - 200	2.0 - 5.0 - 8.0 2.0 - 5.0 - 8.0	0.4 - 0.6 - 0.8 0.3 - 0.5 - 0.7		
	Roughing (Low Cutting Force)	Continuous Interruption	PX (Single-sided)	CA515 CA025P	1.2 1.6	120 - 180 - 230 100 - 150 - 200	2.0 - 5.0 - 8.0 2.0 - 5.0 - 8.0	0.4 - 0.6 - 0.8 0.3 - 0.5 - 0.7		
	Finishing (High Speed Machining)	Continuous	PP	CCX	0.8	200 - 300 - 400	0.2 - 0.5 - 1.5	0.04 - 0.16 - 0.28		
	Finishing (Gloss Oriented)	Continuous Interruption	PP	TN610 TN620	0.4 0.8	150 - 200 - 280 140 - 180 - 240	0.2 - 0.5 - 1.5 0.2 - 0.5 - 1.5	0.04 - 0.16 - 0.28 0.05 - 0.2 - 0.35		
	Finishing (Tool Life Oriented)	Continuous Interruption	PP	PV710 CA515	0.4 0.8	120 - 180 - 260 100 - 150 - 200	0.2 - 0.5 - 1.5 0.2 - 0.5 - 1.5	0.04 - 0.16 - 0.28 0.05 - 0.2 - 0.35		
	Finishing - Medium	Continuous Interruption	PQ	CA515 CA025P	0.8 0.8	120 - 160 - 220 100 - 140 - 180	0.5 - 1.5 - 2.5 0.5 - 1.5 - 2.5	0.15 - 0.25 - 0.3 0.15 - 0.2 - 0.25		
	Medium - Roughing	Continuous Interruption	PG	CA515 CA025P	0.8 0.8	120 - 150 - 200 100 - 130 - 180	1.0 - 2.0 - 3.0 1.0 - 2.0 - 3.0	0.2 - 0.3 - 0.5 0.15 - 0.2 - 0.3		
	Medium - Roughing High Feed Rate	Continuous Interruption	PT	CA515 CA025P	0.8 1.2	100 - 140 - 180 80 - 120 - 160	1.5 - 3.0 - 4.5 1.5 - 3.0 - 4.5	0.25 - 0.35 - 0.45 0.25 - 0.35 - 0.45		
	Roughing High Feed Rate	Continuous Interruption	PH	CA515 CA025P	1.2 1.6	100 - 140 - 180 80 - 120 - 160	2.0 - 5.0 - 8.0 2.0 - 5.0 - 8.0	0.4 - 0.6 - 0.8 0.3 - 0.5 - 0.7		
	Roughing (Low Cutting Force)	Continuous Interruption	PX (Single-sided)	CA515 CA025P	1.2 1.6	100 - 140 - 180 80 - 120 - 160	2.0 - 5.0 - 8.0 2.0 - 5.0 - 8.0	0.4 - 0.6 - 0.8 0.3 - 0.5 - 0.7		

D
External

Recommended Cutting Conditions - External Turning (Negative Insert) [ap indicates radius]

ISO Classification	Workpiece Material	Hardness	Cutting Range	Applications	Recommended Chipbreaker	Recommended Insert Grade	Corner-R (RE)	Lower Limit - Recommendation - Upper Limit		
								Vc (m/min)	ap (mm)	f (mm/rev)
M	Stainless Steel (Austenitic related)	HB ≤ 220	Finishing (Gloss Oriented)	Continuous Interruption	PQ	TN620	0.8	120 - 160 - 200	0.5 - 1.0 - 1.5	0.08 - 0.15 - 0.2
			Finishing	Continuous Interruption	MQ	CA6515 CA6525	0.4 0.8	120 - 180 - 240 100 - 160 - 220	0.5 - 1.0 - 1.5 0.5 - 1.0 - 1.5	0.08 - 0.15 - 0.2 0.05 - 0.1 - 0.15
			Medium - Roughing (Chip Control Oriented)	Continuous Interruption	MS	CA6515 CA6525	0.4 0.8	120 - 160 - 200 80 - 140 - 180	1.0 - 2.0 - 3.0 1.0 - 2.0 - 3.0	0.1 - 0.2 - 0.3 0.2 - 0.3 - 0.4
			Medium - Roughing (Sharpness Oriented)	Continuous Interruption	MU	CA6515 CA6525	0.4 0.8	120 - 160 - 200 80 - 140 - 180	1.0 - 2.0 - 3.0 1.0 - 2.0 - 3.0	0.15 - 0.25 - 0.35 0.15 - 0.25 - 0.3
			Roughing	Continuous Interruption	Standard	CA6515 CA6525	0.8 1.2	100 - 140 - 180 80 - 120 - 150	1.0 - 2.0 - 4.0 1.0 - 2.0 - 4.0	0.2 - 0.3 - 0.4 0.2 - 0.3 - 0.4
	Stainless Steel (Precipitation Hardening)	HB ≤ 300	Finishing (Gloss Oriented)	Continuous Interruption	PQ	TN620	0.8	100 - 120 - 150 80 - 100 - 120	0.5 - 1.0 - 1.5 0.5 - 1.0 - 1.5	0.05 - 0.1 - 0.15 0.05 - 0.08 - 0.1
			Finishing	Continuous Interruption	MQ	CA6515 CA6525	0.4 0.8	100 - 120 - 150 80 - 100 - 120	0.5 - 1.0 - 1.5 0.5 - 1.0 - 1.5	0.08 - 0.15 - 0.2 0.05 - 0.1 - 0.15
			Medium - Roughing (Chip Control Oriented)	Continuous Interruption	MS	CA6515 CA6525	0.4 0.8	100 - 120 - 150 80 - 100 - 120	1.0 - 1.5 - 2.0 1.0 - 2.0 - 3.0	0.1 - 0.15 - 0.25 0.1 - 0.15 - 0.2
			Medium - Roughing (Sharpness Oriented)	Continuous Interruption	MU	CA6515 CA6525	0.4 0.8	100 - 120 - 150 80 - 100 - 120	1.0 - 1.5 - 2.0 1.0 - 2.0 - 3.0	0.1 - 0.15 - 0.25 0.1 - 0.15 - 0.2
			Roughing	Continuous Interruption	Standard	CA6515 CA6525	0.8 1.2	80 - 100 - 120 60 - 80 - 100	1.0 - 2.0 - 3.0 1.0 - 2.0 - 4.0	0.2 - 0.3 - 0.4 0.2 - 0.3 - 0.4
K	Gray Cast Iron	HB ≤ 250	High Speed Machining	Continuous Interruption	Without Chipbreaker	KBN475 KBN900 KBN900	0.8 1.2 1.2	400 - 800 - 1,200 500 - 900 - 1,200 500 - 700 - 900	0.05 - 0.2 - 0.5 0.1 - 0.5 - 1.0 0.5 - 1.0 - 1.5	0.1 - 0.2 - 0.3 0.05 - 0.1 - 0.2 0.05 - 0.1 - 0.2
			Finishing (Gloss Oriented)	Continuous Interruption	Standard	PV7005 PV720	0.8 0.8	300 - 350 - 400 150 - 200 - 300	0.5 - 1.0 - 1.5 0.5 - 1.0 - 1.5	0.1 - 0.2 - 0.3 0.08 - 0.15 - 0.2
			Finishing (Ceramic)	Continuous Interruption	Without Chipbreaker	KA30 PT600M	1.2 0.8	300 - 500 - 700 300 - 450 - 600	0.3 - 0.5 - 1.0 0.3 - 0.5 - 1.0	0.1 - 0.2 - 0.3 0.1 - 0.2 - 0.3
			Medium (Ceramic)	Continuous Interruption	Without Chipbreaker	CS7050 KS6050	1.2 1.2	300 - 450 - 550 250 - 400 - 500	1.0 - 2.0 - 3.0 1.0 - 2.0 - 3.0	0.15 - 0.25 - 0.35 0.15 - 0.2 - 0.3
			Medium	Continuous Interruption	KH	CA310 CA315	0.8 1.2	200 - 250 - 300 150 - 200 - 250	0.5 - 2.0 - 2.5 0.5 - 2.0 - 2.5	0.1 - 0.2 - 0.3 0.08 - 0.15 - 0.2
			Roughing	Continuous Interruption	KH	CA310 CA315	0.8 1.2	200 - 250 - 300 150 - 200 - 250	1.0 - 2.0 - 4.0 1.0 - 2.0 - 4.0	0.2 - 0.3 - 0.4 0.2 - 0.3 - 0.4
	Nodular Cast Iron	HB ≤ 270	High Speed Machining	Continuous Interruption	Without Chipbreaker	KBN60M PT600M	0.4 0.8	200 - 300 - 400 200 - 250 - 350	0.1 - 0.3 - 0.5 0.1 - 0.5 - 1.0	0.1 - 0.15 - 0.2 0.1 - 0.2 - 0.4
			Finishing (Gloss Oriented)	Continuous Interruption	Standard	PV7005 PV720	0.8 0.8	150 - 250 - 300 120 - 200 - 250	0.5 - 1.0 - 1.5 0.5 - 1.0 - 1.5	0.1 - 0.2 - 0.3 0.08 - 0.15 - 0.2
			Medium	Continuous Interruption	KG	CA310 CA315	0.8 1.2	150 - 200 - 250 120 - 180 - 220	0.5 - 2.0 - 2.5 0.5 - 2.0 - 2.5	0.1 - 0.2 - 0.3 0.08 - 0.15 - 0.2
			Roughing	Continuous Interruption	KG KH	CA315 CA320	0.8 1.2	150 - 200 - 250 120 - 180 - 220	1.0 - 2.0 - 4.0 1.0 - 2.0 - 4.0	0.2 - 0.3 - 0.4 0.2 - 0.3 - 0.4
N	Non-ferrous Metals Copper Alloy Aluminum Aluminum Alloys	HB ≤ 100	High Speed Machining (Rainbow Surface Gross)	Continuous Interruption	Without Chipbreaker	KPD001	0.4	300 - 800 - 2,000	0.05 - 0.5 - 1.0	0.05 - 0.1 - 0.15
			Finishing (Long Tool Life)	Continuous Interruption	A3	PDL025	0.4 0.8	400 - 500 - 700 400 - 500 - 700	0.5 - 1.0 - 2.0 0.5 - 1.0 - 2.0	0.1 - 0.2 - 0.25 0.1 - 0.2 - 0.25
			Finishing	Continuous Interruption	A3	KW10	0.8 0.8	400 - 500 - 700 400 - 500 - 700	0.5 - 1.0 - 2.0 0.5 - 1.0 - 2.0	0.1 - 0.2 - 0.25 0.1 - 0.2 - 0.25
			Medium	Continuous Interruption	AH	KW10	0.8 0.8	200 - 300 - 500 200 - 300 - 500	1.0 - 2.0 - 3.5 1.0 - 2.0 - 3.5	0.1 - 0.3 - 0.4 0.1 - 0.3 - 0.4
S	Titanium Alloys	HB ≤ 400	Precision Finishing (Rainbow Surface Gross)	Continuous Interruption	Without Chipbreaker	KPD001	0.4 0.4	100 - 150 - 180 70 - 120 - 150	0.05 - 0.3 - 0.5 0.05 - 0.3 - 0.5	0.03 - 0.1 - 0.15 0.03 - 0.07 - 0.1
			Finishing	Continuous Interruption	MQ	SW05	0.4 0.4	40 - 70 - 100 40 - 70 - 100	0.2 - 0.5 - 1.0 0.2 - 0.5 - 1.0	0.05 - 0.2 - 0.3 0.05 - 0.15 - 0.2
			Medium	Continuous Interruption	MU	SW05	0.8 0.8	40 - 60 - 80 40 - 60 - 80	0.5 - 1.0 - 3.0 0.5 - 1.0 - 3.0	0.1 - 0.25 - 0.35 0.1 - 0.2 - 0.3
	Heat-resistant Alloys	HB ≤ 350	Finishing	Continuous Interruption	MQ	PR005S PR015S	0.4 0.8	30 - 55 - 90 25 - 45 - 70	0.2 - 0.3 - 1.0 0.2 - 0.5 - 1.0	0.05 - 0.08 - 0.15 0.05 - 0.1 - 0.2
			Medium	Continuous Interruption	SQ	PR005S PR015S	0.8 0.8	30 - 55 - 90 25 - 45 - 70	0.3 - 0.5 - 1.5 0.3 - 0.5 - 1.5	0.1 - 0.17 - 0.35 0.1 - 0.17 - 0.35
			Roughing	Continuous Interruption	SX	PR005S PR015S	-	30 - 55 - 90 25 - 45 - 70	0.5 - 2.0 - 4.0 0.5 - 2.0 - 4.0	0.15 - 0.3 - 0.45 0.15 - 0.3 - 0.45
H	Hardened Steel Hard Materials	40~50 HRC	Finishing	Continuous Interruption	PQ Standard	CA515	0.8 0.8	60 - 100 - 120 30 - 50 - 70	0.1 - 0.3 - 0.5 0.1 - 0.3 - 0.5	0.05 - 0.08 - 0.1 0.05 - 0.08 - 0.1
			Finishing	Continuous Interruption	Without Chipbreaker	PT600M	0.8 1.2	60 - 80 - 100 30 - 40 - 60	0.2 - 0.5 - 0.7 0.2 - 0.5 - 0.7	0.05 - 0.1 - 0.15 0.05 - 0.1 - 0.15
		50~68 HRC	Finishing	Continuous Interruption	ME MET	KBN05M	0.8 1.2	100 - 150 - 200 90 - 140 - 180	0.05 - 0.3 - 0.5 0.05 - 0.3 - 0.5	0.05 - 0.08 - 0.1 0.05 - 0.08 - 0.1
			Medium	Continuous Interruption	Without Chipbreaker	KBN900	1.2	80 - 100 - 120	0.5 - 1.0 - 2.0	0.05 - 0.1 - 0.2
			Medium	Continuous Interruption	Without Chipbreaker	KBN900	Radius	70 - 90 - 110	0.3 - 0.7 - 1.0	0.05 - 0.1 - 0.15

Insert Grades
Turnable Inserts
CNM & PCD Tools
External
Small Parts
Boring
Grooving
Cut-off
Threading
Drilling
Milling
Tools for
Spare Parts
Technical
Index

A
B
C
D
E
F
G
H
J
K
M
N
P
R
T